

The Interim Water Code For Sierra Leone

Transmission, Distribution and Reticulation System

Version 1.0

Sierra Leone Electricity & Water Regulatory Commission

MARCH 2021

PREFACE

Requirement for a Technical Document

The Interim Water Code for Sierra Leone and other referenced documents, sets regulator's requirements for:

- a) Minimum acceptable technical criteria for design and construction of water supply networks; and
- b) Supply of associated products and materials.

This set of documentation has a number of benefits. It:

- a) facilitates ready acquisition from different suppliers of assets of a recognised acceptable quality;
- b) assures assets have acceptable levels of construction-ability, operability and maintainability;
- c) takes account costing related to asset life;
- d) facilitates efficient design and construction i.e. it reduces the need for the related water authorities to develop and maintain its own standards;
- e) limits risk exposure of the principal and suppliers;
- f) facilitates controlled improvements to asset designs, use of products and materials and methods of construction and acceptance testing; and
- g) facilitates quality assurance and inspection.
- h) This document will be reviewed after every half a decade

ACKNOWLEDGEMENT

This Interim Water Code for Sierra Leone, was initially drafted by international consultants (AARC), under the Regulatory Strengthening and Tariff Determination project which formed a core part of the Millennium Challenge Corporation's Threshold Programme for Sierra Leone.

The detailed review of the initial draft was done by the Water Code Committee (WCC), which comprised of the following members:

Ing. Philip K. Lansana – Minister of Water Resources, SL
Ing. John Bosco Kaikai – EWRC, WCC Chairman
Ing. Michael M. Kargbo – EWRC, WCC Editor and Coordinator
Ing. Christian S. Kallon – EWRC, WCC Editor and Coordinator Assistant
Ing. Nyakeh J. Kamara – EWRC, WCC Editor and Coordinator Assistant
Mr. John Sellu Kpaka – EWRC, WCC Editor and Coordinator Assistant
Dr. Emmanuel Mannah – Director General of the EWRC
Ing. Prince Moore – Sourie – GVWC
Ing. Ibrahim C. Bah – GVWC
Ing. Sahr Sinah – SALWACO
Ing. Marilyn George – SALWACO
Mr. Carl Neel Kamara – SALWACO
Ms. Chrisla Koroma – SALWACO
Ing. Ronnie Benjamin – SLIE
Ing. Zainald I. Dillet – SLIE
Ing. Alvin Benjamin – SLIE
Ing. Amadu Barrie – FBC
Ing. Davephine Tholley – Water4Ever
Mr. Samuel Turay – Water4Ever
Mr. Abu Kargbo – MoHS
Mr. Manish K. Tyagi – GSS
Mr. Abu Bakarr Kamara – NWRMA
Ms. Bintu Kamara – NFF
Mr. Jonathan Campbell – NFF
Mr. Mohamed Fofana - SLSB
Ing. Monica Kamara – MWPA
Mrs. Mariam M. Senessie – MLGRD
Ing. Francis Moijue – MWR
Mr. Augustine Tucker – MWR
Mr. Foday L. Kamara – CPA
Mr. Michael J. Anthony – MoEnv.
Mr. Abdul Karim Marah – FCC
Mr. Bashiru Kargbo – EPA
Mr. Amin Hudroge – SLPBWO
Ing. Olayemi H. Kallon – MCCU
Ing. Ansumana Swarray – MCCU
Ms. Fatmata Barrie – MCCU
Mrs. Ngozi Obi Sesay – EWRC
Mr. Komba Ngongou – EWRC

EXECUTIVE SUMMARY

Scope of Code

This Code focuses on technical requirements for design and construction of water infrastructure and specifications for infrastructure products.

The Interim Water Code for Sierra Leone covers the planning, design and construction of transmission / trunk, distribution and reticulation drinking water mains and service pipes nominally from 15 mm (½ inch) upwards.

Code Purpose

The primary objective of the Interim Water Code for Sierra Leone is to document best practice for design and construction of water supply networks. The Code is an element of the overall asset management framework that the regulator, Electricity and Water Regulatory Commission (EWRC) in collaboration with the Ministry of Water Resources (MWR) is developing for the water network infrastructure. The Code focuses on asset creation, but it could be used for some other purposes such as replacement and renewal of water supply assets.

The Code is intended for Planners, Designers and service providers servicing the water sector and for water infrastructural contract work done on behalf of Development partners, Non-Governmental Organizations (NGO) and Ministries Department and Agencies (MDA).

The Code does not provide administrative or process guidance that is specific to an individual or group.

Purchase Specifications

The code also provides details of Purchase Specifications for “standard” products and materials used to construct water supply network infrastructure conforming to the acceptable international best practice.

Project-specific variations to these specifications stated in the appendix below or alternative specifications may be permitted by the responsible procuring units in consultation with the relevant Water Authority in Sierra Leone.

It is anticipated that Purchase Specifications will be revised over the life of this Code to reflect changes in Standards and advice from users.

Quality Assurance

Each Purchase Specification nominates default quality assurance requirements for the product. The range of quality assurance options is based on international best practice. At the time of placing an order, it is recommended that the purchaser (e.g. Contractors) require the product supplier to declare that products delivered conform to the nominated “standard” relevant to the relevant Purchase Specification. The declaration should be additional to the default quality assurance requirement for the product.

Packaging, Transportation and Delivery

The Code does not specify packaging, transportation and delivery requirements for related goods. It is deemed that the supplier is responsible for all insurances and ensuring that products are not damaged in any way during packaging, transportation and unloading at the purchaser’s nominated delivery location. It is assumed that purchaser’s procurement processes address this requirement and verified by the responsible procuring entities.

Products, Material Information and Guidance

The Regulator in collaboration with the Ministry of Water Resources will develop Products, material information and guidance to assist Designers and service providers in specifying the most suitable products and materials for constructing water networks and to help Contractors understand relevant aspects of installation of the different pipeline systems and their components.

TABLE OF CONTENTS

PREFACE	ii
Requirement for a Technical Document	ii
ACKNOWLEDGEMENT	iii
EXECUTIVE SUMMARY	iv
Scope of Code	iv
Code Purpose	iv
Purchase Specifications	iv
Quality Assurance	iv
Packaging, Transportation and Delivery	iv
Products, Material Information and Guidance	v
LIST OF TABLES	xiv
LIST OF FIGURES	xiv
ACRONYMS AND ABBREVIATIONS	xvi
SECTION 1 - GENERAL	1
1 GENERAL	2
1.1 Scope	2
1.2 Preparation and Design	3
1.2.1 Objectives	3
1.2.2 Scope and requirements	3
1.2.3 Concept plan format	4
1.2.5 Detailed design	4
1.2.5.1 Designer's needs and responsibilities	4
1.2.5.2 Requirements to be addressed	5
1.2.5.3 Design outputs	5
1.2.6 Design life	6
1.3 Consultation with other parties	6
SECTION 2 - DESIGN CONCEPT	7
2 DEMAND, CONFIGURATION AND PLANNING	8
2.1 System Planning	8
2.1.1 General	8
2.2 Demand	8
2.2.1 General	8
2.2.2 Demand assessment	8
2.2.2.1 General	8
2.2.2.2 Residential	8
2.2.3 Peak demands	9
2.2.3.1 General	9
2.2.3.2 Peak day demand	9
2.2.3.3 Peak hour demand	9
2.3 System Hydraulics	9
2.3.1 General	9
2.3.2 Network analysis	9
2.3.3 Operating pressures	10

2.3.3.1	Service pressure	10
2.3.3.2	Maximum allowable service pressure	10
2.3.3.3	Minimum service pressure	10
2.3.4	Pressure variation analysis	11
2.4	Water Quality	11
2.4.1	General	11
2.4.2	Prevention of back siphonage	11
2.4.3	Water age.....	11
2.4.4	Disinfection.....	11
2.5	Service Reservoirs	12
2.5.1	Storage capacity	12
2.6	Future System Expansion	12
2.7	System Review.....	13
3.	HYDRAULIC CONCEPTS AND PRESSURE CLASS	14
3.1	Sizing.....	14
3.1.1	General	14
3.1.4	Fire flows.....	15
3.1.5	Sizing by analysis.....	15
3.1.5.1	General.....	15
3.1.5.2	Head losses.....	16
3.1.5.3	Hydraulic roughness values.....	16
3.1.5.4	Flow velocities	16
3.2	Design Pressures	17
3.2.1	General	17
3.2.2	Gravity systems.....	17
3.2.3	Systems subjected to dynamic pressures	18
3.3	Pressure Class of System Components	18
3.3.1	Gravity systems.....	18
3.3.2	Systems subjected to dynamic pressures	18
3.3.3	Minimum pressure class.....	18
3.4	Thrust and anchor block design.....	19
3.5	System test pressure.....	19
3.6	Design for dynamic stresses	19
3.6.1	General	19
3.6.2	Surge.....	19
3.6.3	Fatigue	19
3.6.4	Fatigue de-rating of plastics pipes and fittings	19
3.7	Temperature De-rating of Plastics Pipes and Fittings.....	20
4.	GENERAL DESIGN CONCEPTS AND MAINS	21
4.1	General Requirements	21
4.1.1	Design tolerances	21
4.1.2	Levels.....	21
4.1.3	Environmental considerations	21
4.1.3.1	General.....	21

4.1.3.2 <i>Urban salinity</i>	22
4.2 Reticulation Design for Water Quality	22
4.2.1 Layout of water mains	22
4.3 Water Main Access.....	22
4.4 Location of Water Mains	22
4.4.1 General	22
4.4.2 Water mains in road reserves	22
4.4.2.1 <i>General</i>	22
4.4.2.2 <i>Location in footway</i>	23
4.4.2.3 <i>Location in carriageway</i>	24
4.4.2.4 <i>Location in roundabouts and Laybys</i>	24
4.4.3 Location in other than dedicated public road reserves	24
4.4.4 Effect on vegetation	24
4.4.5 Water mains near trees	24
4.4.6 Crossings	24
4.4.6.1 <i>General</i>	24
4.4.6.2 <i>Requirements for encased pipe installations</i>	25
4.4.7 Railway reserves.....	25
4.4.8 Crossings of creeks or drainage reserves	27
4.4.9 Overhead power lines and transmission towers	27
4.4.10 Marking tape	27
4.4.10.1 <i>General</i>	27
4.4.10.2 <i>Mains</i>	27
4.4.10.3 <i>Property services</i>	27
4.5 Rider Mains	28
4.6 Connection of new mains to existing mains.....	28
4.7 Termination Points.....	29
4.7.1 Permanent ends of water mains.....	29
4.7.2 Temporary ends of water mains	29
4.7.3 Chlorination assemblies	29
4.7.4 Flushing points	30
4.8 Property Services	31
4.8.1 General	31
4.8.2 Connections to water mains	33
4.8.3 Services, Outlets and Water Meters.....	33
4.9 Obstructions and Clearances	34
4.9.1 General	34
4.9.2 Surface obstructions.....	34
4.9.3 Clearance from structures and property boundaries	34
4.9.4 Underground obstructions and services	34
4.9.4.1 <i>General</i>	34
4.9.4.2 <i>Clearance requirements</i>	34
5. PRESSURE BOOSTING AND MANAGEMENT	35
5.1 General.....	35

5.2 In-line Pressure Booster Pumping Stations	35
5.2.1 Planning criteria	35
5.2.2 Concept design	35
5.2.2.1 General	35
5.2.2.2 Life cycle considerations	35
5.2.2.3 Functionality	35
5.2.2.4 Due diligence requirements	36
5.2.2.5 Reliability	36
5.2.2.6 Maintainability	36
5.2.2.7 Materials design	37
5.2.3 Commissioning plan	37
5.2.3.1 General	37
5.2.3.2 Pre-commissioning	37
5.2.3.3 Commissioning	38
5.2.4 System planning and modelling	38
5.2.4.1 Modelling	38
5.2.4.2 Minimum pressure affecting the area	38
5.2.4.3 Number of affected properties within the low pressure zone	38
5.2.5 Booster design	39
5.2.5.1 General	39
5.2.5.2 Connection to the network	39
5.2.5.3 Maximum flow and pressure requirements	39
5.2.5.4 Design for minimum pressure boost conditions	39
5.2.5.5 Design for minimum flow conditions	39
5.2.5.6 Booster configuration design	40
5.2.5.7 Booster set and pump selection	40
5.2.5.8 Booster pipework and manifold design	41
5.2.6 Pressure accumulator tank	42
5.2.7 Control and telemetry system	42
5.2.7.1 General	42
5.2.7.2 System requirements	42
6. STRUCTURAL CONCEPTS AND FORCES ON PIPEWORKS	44
6.1 General	44
6.2 Structural Considerations	44
6.3 Internal Forces	44
6.4 External Forces	44
6.4.1 General	44
6.4.2 Pipe cover	46
6.4.3 Pipe embedment	46
6.4.4 Buoyancy	47
6.5 Geotechnical Considerations	48
6.5.1 General	48
6.5.2 Construction of an embankment	48
6.6 Concrete Encasement	48

6.6.1 General	48
6.7 Pipeline Anchorage	49
6.7.1 General	49
6.7.2 Thrust blocks.....	49
6.7.2.1 <i>General</i>	49
6.7.2.2 <i>Concrete thrust blocks</i>	50
6.7.3 Anchor blocks.....	53
SECTION 3 - PIPELINES AND APPURTENANCES.....	54
7. PIPELINE SYSTEMS AND PROTECTION.....	55
7.1 General.....	55
7.1.1 Water supply mains – drinking water	55
7.1.2 Property services – drinking water	55
7.1.3 Marking tapes.....	56
7.2 Ductile Iron Pipeline Systems.....	56
7.2.1 Sizes and configurations	56
7.2.2 Seal coating of lining	57
7.2.3 Sleeving	57
7.2.4 Screw-on flanges for DI pipes	57
7.2.5 Flanged joints.....	57
7.3 PVC-U Pipeline Systems.....	57
7.4 PE Pipeline Systems	58
7.5 Steel Pipeline Systems.....	58
7.5.1 Sizes and configurations	58
7.5.2 Joints.....	58
7.5.3 Field welding	58
7.5.4 Flanged joints.....	59
7.6 Protection against Degradation	60
7.6.1 Application.....	60
7.6.2 Protection against aggressive environments.....	60
7.6.3 Protection against damage to coatings	60
7.6.4 Stainless Steel	60
7.6.4.1 <i>Grade selection</i>	60
7.6.4.2 <i>Welding</i>	61
7.6.4.3 <i>Threaded components</i>	61
7.6.5 Cathodic protection	61
7.6.6 Stray current corrosion	62
7.6.7 Protection against contaminated ground	62
7.6.8 Bolted connections.....	63
8. VALVES, SCOURS AND ANCILLARY PIPELINE PRODUCTS	65
8.1 Valve – General.....	65
8.1.1 Valving design.....	65
8.1.2 Valve siting principles.....	65
8.1.3 Selection considerations	65
8.1.4 Local in-line booster pumping stations	65

8.2 Stop Valves	66
8.2.1 Installation design and selection criteria	66
8.2.1.1 General	66
8.2.1.2 Gate valves	66
8.2.1.3 Butterfly valves	67
8.2.2 Stop valves for transfer/ transmission mains	67
8.2.3 Stop valves for reticulation mains	67
8.2.4 Stop valves for local in-line booster pumping stations	67
8.2.5 Bypass of stop valve	68
8.3.1 Pressure reducing valves (PRV)	68
8.3.2 Pressure relief valves (PRelV)	68
8.3.3 Pressure sustaining valves (PSV)	69
8.4 Air Valves (AV)	69
8.4.1 Installation design criteria	69
8.4.2 Air valves type	70
8.4.3 Air valves size	70
8.4.4 Air valves location	70
8.4.5 Use of hydrants as an alternative to air valves	70
8.4.6 Water sampling via air valves	71
8.5 Non-Return Valves	71
8.5.1 Installation design criteria	71
8.5.2 Typical installations of non-return valves	71
8.6 Scours and Pump-out Branches	71
8.6.1 Location and arrangements	71
8.6.2 Design	71
8.6.3 Scour size	72
8.6.4 Scour location	72
8.7 Swabbing Points	72
8.8 Hydrants	72
8.8.1 Purposes	72
8.8.2 Hydrant siting principles	72
8.8.3 Hydrant types	72
8.8.4 Hydrant size	73
8.9 Disinfection Facilities	73
8.9.1 General	73
8.9.2 Reticulation mains	73
8.9.3 Transfer and distribution mains	73
SECTION 1 - GENERAL	75
9 GENERAL	76
9.1 Order of Construction, Testing and Commissioning	76
9.2 Customer Focus	76
9.3 Protection of Property and Environment	76
9.4 Road opening permits	77
SECTION 2 – PRODUCT MANAGEMENT AND INSTALLATION	78

10 PRODUCTS AND MATERIALS.....	79
10.1 Delivery Inspection of Products and Materials.....	79
10.2 Transportation, Handling and Storage of PRODUCTS AND MATERIALS.....	79
10.2.1 General.....	79
10.2.2 Transportation.....	79
10.2.3 Unloading and handling.....	79
10.2.4 On-site storage.....	80
10.3 Rejected Products and Materials.....	80
10.4 Concrete Works.....	80
10.5 Supply of Water to the Works.....	81
10.6 Supply of Water to existing properties.....	81
10.7 Under Pressure Cut-in Connection to Pressure pipes \geq DN 80.....	81
10.7.1 Flanged off-takes.....	81
10.7.2 Valves.....	81
10.7.3 Flange holes.....	81
10.7.4 Gaskets.....	81
10.7.5 Bolting system.....	82
10.7.5.1 General.....	82
10.7.5.2 Carbon or alloy steel bolt assemblies.....	82
10.7.5.3 Stainless steel bolt assemblies.....	82
10.7.6 Insulation sleeves.....	82
11 EXCAVATION.....	83
11.1 Precautions.....	83
11.2 Limits of Clearing and Excavation.....	83
11.3 Protection of Trees.....	83
11.3.1 General precautions.....	83
11.3.2 Protection of roots.....	83
11.4 Blasting.....	83
11.5 Support of Excavations.....	83
11.6 Drainage and Dewatering.....	84
11.7 Under Pressure Cut-in Connection to pressure pipes \geq DN 80.....	84
11.7.1 Excavation requirements.....	84
11.7.2 Extent of excavation.....	84
11.8 Trench Excavation.....	85
11.8.1 General.....	85
11.8.2 Construction of embankment.....	85
11.8.3 Clearances for on-site works.....	85
11.9 Refill of excessive excavation.....	85
12 PIPE EMBEDMENT AND SUPPORT.....	86
12.1 General.....	86
12.2 Embedment Materials.....	86
12.2.1 General.....	86
12.3 Compaction of Embedment.....	86
12.4 Bedding for pipes.....	86

12.4.1 Trench Floor Preparation	86
12.4.2 Bedding and Pipe Support	87
13 PIPE INSTALLATION	88
13.1 Installation of pipes.....	88
13.1.1 General	88
13.1.2 Cleaning, inspection and joint preparation	88
13.1.3 Laying.....	88
13.2 Horizontal and Vertical Deflection of Pipes.....	89
13.2.1 General	89
13.2.2 Deflection at a pipe joint	89
13.2.3 Curving of pipe.....	89
13.3 Under-pressure Cut-in Connection to Pressure Pipes \geq DN 80.....	89
13.3.1 Inspection of host pipe	89
13.3.2 Inspection of valve to be installed	89
13.3.3 Disinfection of fittings and equipment.....	89
13.3.4 Installation of the valve.....	90
13.3.5 Cut-in operation.....	90
13.4 Floatation Control	90
13.5 Thrust and Anchor Blocks and Restrained Joints.....	91
13.6 Tapping of Mains, Property Services and Water Meters	91
13.7 Marking Tapes.....	92
13.7.1 Non-detectable marking tape	92
13.7.2 Detectable marking tape	92
13.8 Scours	92
13.9 Flanged Joints	92
14 TRENCH BACKFILL	93
14.1 Trench Backfill.....	93
14.1.1 Material requirements.....	93
14.1.1.1 Trafficable Areas.....	93
14.1.1.2 Non-Trafficable Areas.....	93
14.1.2 Compaction of trench fill.....	93
14.2 Embankment Fill.....	94
SECTION 3 – PIPELINE CLEANING AND ACCEPTANCE	95
15 SWABBING	96
15.1 General.....	96
15.2 Swabs.....	96
15.3 Swabbing Procedure	96
16 ACCEPTANCE TESTING	97
16.1 General.....	97
16.2 Visual Inspection	97
16.3 Hydrostatic Pressure Testing	97
16.3.1 General	97
16.3.2 Mains.....	97
16.4 Water Quality Testing	98

16.4.1 General	98
16.4.2 Test procedure	98
16.4.3 Failure of test	98
17 DISINFECTION.....	99
17.1 Application.....	99
17.2 Flushing of Disinfection Water	99
ANNEXES.....	100
ANNEX 1 – LIST OF REVIEWERS	100
ANNEX 2 – DEFINITIONS & GLOSSARY	101
REFERENCED DOCUMENTS	114
DRAWINGS	121
SPECIFICATIONS.....	122

LIST OF TABLES

Table 1: TYPICAL ASSET DESIGN LIFE	6
Table 2: MINIMUM PIPE SIZES FOR NEW DEVELOPMENTS.....	14
Table 3: MINIMUM PIPE SIZES FOR EXISTING DEVELOPMENTS	15
Table 4: TEST AND ASSET DESIGN PRESSURES – BASED ON SYSTEM PRESSURE ...	17
Table 5: METHODS FOR DESIGN OF PLASTICS PIPES AND FITTINGS FOR DYNAMIC STRESSES.....	20
Table 6: MINIMUM CLEARANCES FROM OTHER UTILITY ASSETS.....	34
Table 7: FLOW VELOCITIES	41
Table 8: MINIMUM COVER OVER BURIED PIPE	46
Table 9: CONCRETE THRUST BLOCK	51
Table 10: PROPERTIES OF DRINKING WATER COMPONENTS IN A WATER DISTRIBUTION SYSTEM.....	55
Table 11: PROPERTIES OF DRINKING WATER COMPONENTS IN A WATER DISTRIBUTION SYSTEM.....	56

LIST OF FIGURES

Figure 1: TYPICAL WATER SUPPLY NETWORK.....	2
Figure 2: TYPICAL ROADWAY/RAILWAY CROSSING	26
Figure 3: CUT-IN CONNECTION USING MECHANICAL COUPLING.....	28
Figure 4: UNDER PRESSURE CONNECTION METHOD	29
Figure 5: IN-LINE CONNECTION	30
Figure 6: TYPICAL FLUSHING POINT ASSEMBLY	31
Figure 7: ELECTROFUSION (EF) SADDLE DETAILS.....	32
Figure 8: TAPPING BAND ARRANGEMENT	32
Figure 9: TYPICAL PROPERTY SERVICE CONNECTION.....	33
Figure 10: KERB MARKING	33

Figure 11: BURIED PIPE IN A TRENCH SHOWING THE EMBEDMENT AND TRENCHFILL ZONES	45
Figure 12: STANDARD PIPE EMBEDMENT TYPES	47
Figure 13: TYPICAL EMBEDMENT DETAILS FOR LOW BEARING CAPACITY GROUNDS	48
Figure 14: TYPICAL CONCRETE ENCASEMENT EMBEDMENT DETAILS.....	49
Figure 15: TYPICAL NON-RESTRAINED PIPEWORK THRUST BLOCK DETAILS	52
Figure 16: TYPICAL CONCRETE THRUST BLOCKS FOR VALVES INCLUDING RESTRAINT MECHANISM	53
Figure 17: TYPICAL INSULATED FLANGED JOINT FOR CATHODICALLY PROTECTED STEEL MAINS	59
Figure 18: TYPICAL BOLTED CONNECTION DETAIL FOR FUSION BONDED COATED DUCTILE IRON FLANGES WITH STAINLESS STEEL FASTENERS	63
Figure 19: TYPICAL BOLTED CONNECTION DETAIL AND CORROSION PROTECTION PROCEDURE FOR BURIED DUCTILE IRON FLANGES WITH GALVANISED STEEL FASTENERS	64
Figure 20: TYPICAL BOLTED CONNECTION DETAIL FOR PE STUB FLANGE AND RAISED DUCTILE IRON FLANGE WITH STAINLESS STEEL FASTENERS AND BACKING PLATE	64
Figure 21: PE STUB FLANGE, SS316 BACKING RING AND FLANGE ASSEMBLY	92

ACRONYMS AND ABBREVIATIONS

ABBREVIATION	INTERPRETATION
%	percentage
AHBP	allowable horizontal bearing pressure
AICV	automatic inlet control valves
ASCE	American Society of Civil Engineers
ASTM	American Society for Testing Materials
AV	Air valve
AWWA	American Water Works Association
BS	British Standard
BSP	British Standard Pipe
CLSM	Controlled low strength material
cm	Centimetre
CP	Cathodic Protection
CV hydrant	Control-valved hydrant
DC	Direct Current
DI	Ductile Iron
DICL	Ductile Iron Cement (mortar) lined
DN	Nominal size designation (based on internal or external diameter)
EIA	Environmental Impact Assessment
FBPE	Fusion Bonded Polyethylene
FSL	1 finished surface level 2 full storage level (of a reservoir)
g/m ²	grams/square metre
GIS	geographical information system
GPS	Global Positioning System
h	hour
H	Pressure head (in metres). H can also be represented as mH
ha	hectare
HGL	Hydraulic Grade Line
Hz	hertz
ID	Internal Diameter
ID	Density Index
I/O	input/output
ISO	International Standards Organisation
ITP	inspection and test plan
ks	equivalent sand roughness size
kL	kilolitre
km	kilometre
kPa	kilopascal

kV	Kilovolt
L	litre
lb	depth of bedding
lc	width of side wall support
lo	depth of overlay
L	litre
LP	pipe length
L/s	litres per second
m	metre
mH	metres head
ml	millilitre
m/s	metres per second
MAOP	maximum allowable operating pressure
mg/L	milligrams/litre
mm	millimetre
MPa	megapascal
NDH	no discharge head
NPSHA	net positive suction head available
NTU	nephelometric turbidity unit
o	degree
oC	degree Celsius
OD	outside diameter
OH&S	occupational health and safety
PDF	peak day factor
PE	polyethylene
PFD	process flow diagram
PHF	peak hour factor
PN	nominal pressure, in megapascals X 10
PPE	personal protection equipment
PREN	pitting resistance equivalent number
PreIV	pressure relief valve
PRV	pressure reducing valve
PSV	pressure sustaining valve
PTFE	polytetrafluoroethylene
PUA	potentially unstable area
PVC	polyvinylchloride
PVC-U	polyvinylchloride unplasticised
Q	flow (in metres/second)
RD	density ratio
REF	review of environmental factors
RSL	reserve storage level

RTU	remote terminal unit
RV	reflux valve
SCADA	supervisory control and data acquisition
MSCL	Mild steel cement (mortar) lined
SDR	standard dimension ratio
SLD	Sierra Leone Datum (The ministry of Lands in Sierra Leone, Considers WGS 84, 28 and 29)
SN	nominal stiffness, in N/m/m X 10-3
SS	stainless steel
STP	system test pressure
UPCIC	under pressure cut-in connection
UV	ultraviolet
VSD	variable speed drive
WAC	Work As Constructed
WPS	Water Pumping Station

Document 1- Standards and Design

Section 1 - General

1 GENERAL

1.1 Scope

Standards and Design describe requirements for preparation and design of drinking water transmission, distribution and reticulation networks. It is applicable for servicing new developments and re-development areas, as well as for watermain augmentations and renewals. A typical schematic of a water supply system provided for in this code is shown in Figure 1 below.

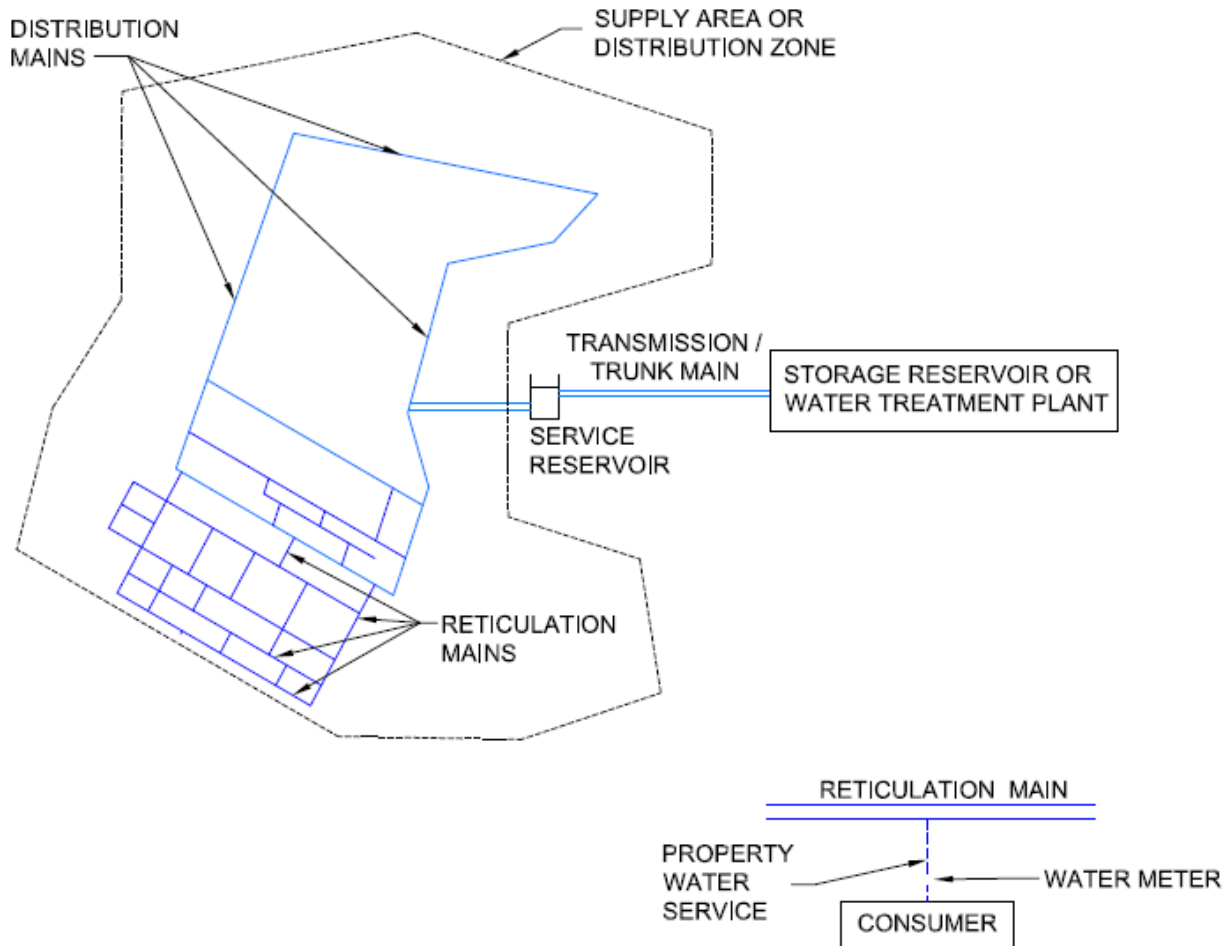

Figure 1: TYPICAL WATER SUPPLY NETWORK

1.2 Preparation and Design

1.2.1 Objectives

The overall objective of system preparation and design is to provide a water supply system that meets the relevant Water Authority's obligations under its operating licence and customer contract for water quality, continuity of supply and pressure at the draw-off point.

1.2.2 Scope and requirements

Preparation and design processes for portable water supply systems including reservoirs, treatment plants, transmission, distribution and reticulation mains, pumping stations and associated control systems. Works shall address all appropriate due diligence requirements, including obligations under operating licences, customer contracts and regulations pertaining to health, environment, security and Operational Health and Safety (OH&S).

System plans and designs shall ensure that, under normal operating conditions and maintenance practices:

- a) transmission systems, including storage reservoirs and pumping stations are capable of meeting daily peak demands;
- b) Non-revenue Water (NRW) should be kept at minimum level, according to target levels to be determined by Utility in consultation with the relevant water authority. NRW levels should be catered for, from design to Operation and maintenance stages for all components of the water supply system.
- c) distribution systems, including service reservoirs and pumping stations, are capable of meeting a set proportion of peak day to peak hour demands;
- d) reticulation systems are capable of meeting peak hourly demands; and
- e) isolated portions of reticulation systems, such as pressure boosted areas or areas served by a network of small diameter mains, are capable of meeting peak demands.

Contingency plans may need to be developed to address potential failure of critical assets, reflecting risk assessment relative to normal operating and maintenance practices of the Water system operator. Such plans may include provision for managing:

- a) customer impacts from loss of supply due to mains failure, power outages etc.;
- b) water quality;
- c) alternative supplies;
- d) maintenance response;
- e) adaptation responses to impacts arising from climate change;
- f) community and environmental impacts e.g. flooding, traffic disruption, crime and bushfires;
- g) environmental restoration; and
- h) financial impacts, third-party claims and litigation.

An Environmental Impact Assessment (EIA) is required to be undertaken before completion of the concept and system plans. EIA documentation shall address and conform to legal requirements, the relevant Water Authority guidelines and applicable standards.

Where required, Development/Planning approval(s) shall be obtained from the relevant authority.

1.2.3 Concept plan format

A concept plan shall be developed for each project;

Depending on the Water Authority's requirements and/or scope of a project, the plan format may vary from a layout sketch to a complete system specification. For example, a plan for a reticulation system may simply require notification of the points of connections, service pressure and any special system requirements.

The concept plan shall:

- a) satisfy requirements of relevant OH&S, environmental and security Legislation/Act and/or Regulations;
- b) address route and/or layout of the transfer and network mains, the operations and maintenance of which have the potential to cause traffic disruption especially in potentially congested areas such as major cities and commercial precincts;
- c) minimise the likelihood of pipe, fitting and appurtenance failures especially in the case of critical mains.
- d) identify special requirements of the relevant Water Authority including, but not limited to:
 - i) provision for future expansion of the system and/or required augmentation of the existing system; and
 - ii) critical infrastructure protection.

The plan shall also consider and address as necessary:

- a) Heritage and archaeological aspects.
- b) Land ownership and planning requirements.
- c) Impacts on community.
- d) Alternative water supplies.
- e) Water quality performance.

1.2.5 Detailed design

1.2.5.1 Designer's needs and responsibilities

The Designer shall translate the planning output into a detailed system / network design in the form of Design Drawings and a construction Specification. Design outputs shall be compatible with the Concept Plan. The design shall comply with the design parameters detailed in this Code and/or Water Authority requirements.

The Designer should liaise with the Water Authority and other relevant stakeholders, prior to commencement of design, to ensure that sufficient planning is completed in order to undertake the design.

Figures included in this Code and "typical drawings" made available to Designers should be considered as "typical" or "concept" and are not suitable for construction without further engineering design details and being made project specific.

The Designer requires information such as:

- a) details of acceptable connection point(s);
- b) details of available flow (Q) at the connection point;
- c) details of available pressure / head (H) at the connection point.
- d) minimum allowable operating (working) pressure;
- e) maximum allowable operating (working) pressure;
- f) details of any larger "through mains" required for future expansion;
- g) any special requirements for critical mains;
- h) special requirements for firefighting purposes;
- i) water supply zone boundaries; and
- j) options to be considered for provision of supply continuity or alternative supply arrangements.
- k) And other related relevant standards (Zonal plans, etc.)

1.2.5.2 Requirements to be addressed

The design shall provide water supply to each property by way of a connection point to a water main or a pre-laid property service from a water main and shall address, inter alia, the:

- a) National Standards (Including the national Water and Sanitation Policy)
- b) water Utilities policies, customer charters and contracts;
- c) water Utilities standards not otherwise contained or referenced by this Code;
- d) hydraulic adequacy of the system;
- e) ability of the water system to maintain acceptable water quality;
- f) critical infrastructure protection measures;
- g) structural adequacy of system components for the design life;
- h) ease of operation and maintenance of pipeline system components;
- i) OH&S requirements;
- j) environmental requirements including environmental and community impact of the works;
- k) easement requirements;
- l) minimisation of life cycle costs;
- m) resistance of each component to internal and external corrosion or degradation for the design life;
- n) system flexibility and robustness to functional changes; and
- o) constructability and methods of the system.

1.2.5.3 Design outputs

Design Drawings and Specifications for construction purposes shall clearly address the issues of a particular project. The design output shall include, but not be limited to:

- a) Design drawings showing, as appropriate, location of pipelines, valves, hydrants, pipe materials, size, pressure class, jointing methods and corrosion protection measures.
- b) Detailed construction drawings including the location of all relevant obstructions.
- c) Specifications for products, materials, site investigation, excavation / trench details and other technical matters.
- d) Documentation of design assumptions, constraints and issues relevant to the design and not otherwise noted in the Concept Plan or Design Drawings or Specifications and
- e) other related relevant design standards considered.

1.2.6 Design life

Generally, all water supply distribution systems shall be designed for a nominal asset life of at least 60 years without rehabilitation. Some components such as pumps, valves, metering and control equipment may require earlier renovation or replacement.

Typical asset design lives for water supply distribution items are shown in below table 1:

Table 1: TYPICAL ASSET DESIGN LIFE

Item	Water System Mains	Reservoirs	Pumps	Valves	SCADA
Expected Design Life (years)	60	50	15	20	10

1.3 Consultation with other parties

Planners and Designers shall consult with principal stakeholders affected by the works.

Stakeholders may include, but are not limited to:

- a) Sierra Leone Roads Authority
- b) Local Councils
- c) Ministry of Water resources
- d) Sierra Leone Fire Force
- e) Water, and electricity Utilities
- f) Ministry of Information
- g) Sierra Leone Environmental Protection Agency
- h) Ministry of Health and Sanitation
- i) National Water Resources Management Agency
- j) Ministry of Lands and Country Planning.
- k) Sierra Leone Standards Bureau
- l) Ministry of Works
- m) Statistics Sierra Leone
- n) Any other relevant stakeholders

Section 2 - Design Concept

2 DEMAND, CONFIGURATION AND PLANNING

2.1 System Planning

2.1.1 General

The designer in consultation with the relevant Water Authority has also to perform a network analysis to analyse the adequacy of the existing system to service the new development. It is also the designer's role to plan all the distribution and reticulation system and all major infrastructure assets within the system.

If it is a new system the designer in consultation with the relevant water authority needs to analyse possible sources of supply and plan all the distribution and reticulation system and all major infrastructure assets within the system.

2.2 Demand

2.2.1 General

The Planner shall:

- a) base the system hydraulic design on the ultimate predicted development and division of the required water supply into drinking water and non-drinking water demands; and
- b) consult the relevant Water Authority and related policy to determine the appropriate demand to be used for each type of development in the design area.

2.2.2 Demand assessment

2.2.2.1 General

The Planner or designer should refer to the relevant Water Authority for the typical peak hour demand rates or determined using the guidelines below.

2.2.2.2 Residential

Determine residential demand by multiplying the relevant peak hour demand per property or unit and the number of properties serviced.

In existing residential areas, estimate the number of properties serviced by either:

- a) a field house count; or
- b) interrogation of census data; or
- c) interrogation of GIS system data; or
- d) a combination of the above

For areas that are yet to be planned and zoned, apply a density factor relevant to the land zoning and the appropriate peak hour demand. Total demands of future supply areas should be considered, being careful to avoid an overly conservative design.

It is expected that the relevant water authorities should be consulted to authorise the actual demand value used for design purposes.

2.2.3 Peak demands

2.2.3.1 General

Refer below clauses for peak day demand and peak hour demand.

2.2.3.2 Peak day demand

Peak day demand, over a 12-month period, required for the design of a distribution system upstream of the balancing storage shall be calculated from:

Peak day demand (also known as 'maximum day demand') = Average day demand x Peak Day Factor (PDF).

In consultation with the relevant water Authorities, the Peak Day Factor can be determined and in accordance with the relevant ISO standard.

Unless specified otherwise by the Water Authority, assume:

PDF = 2 for populations over 15000.

PDF = 2.5 for populations below 5000.

PDF = 2.5 – 3 for areas of high tourism or fluctuations in occupancy.

The factors to be interpolated in between 5000 and 15000.

2.2.3.3 Peak hour demand

Peak hour demand, over a 24-hour period, required for the design of a distribution system downstream of the balancing storage shall be calculated from:

Peak hour demand (also known as 'maximum hour demand') = Average hour demand (on peak day) x Peak Hour Factor (PHF).

In consultation with the relevant water Authorities, the Peak hour demand can be determined and in accordance with the relevant ISO standard.

Unless specified otherwise by the Water Authority, assume:

PHF = 2 for populations over 15000.

PHF = 5 for populations below 5000.

The factors to be interpolated in between 5000 and 15000

2.3 System Hydraulics

2.3.1 General

Transmission, distribution and reticulation mains shall be sized to meet the planned demand at the maximum specified flow rate, having regard to the Water Authority's customer service contract for service pressure, water quality and reliability of supply.

2.3.2 Network analysis

Where a network analysis of the system is required to develop servicing options or a Concept Plan, the system shall be analysed using a calibrated mathematical model authorised by the respective operator in consultation with the relevant Water Authority. The analysis shall include all elements within the system and shall address peak demand conditions for operating / reserve storage and pressure, and average demand conditions for water quality.

2.3.3 Operating pressures

2.3.3.1 Service pressure

Service pressure is location and flow-rate dependent. At any point in the system, service pressure is dependent on the available static head or steady state pumping pressure less hydraulic losses due to demand flows. To obtain the residual pressure head at any given point on the network, the network should be balanced using the Peak flow and fire flows. Operating pressure limit may be specified by the water operator/Designer in consultation with the relevant Water Authority.

Service pressure should be specified by the operator/Designer in consultation with the relevant Water Authority. Residual pressure head largely depend on level on the type of development (height of buildings, land use characteristics, etc).

2.3.3.2 Maximum allowable service pressure

An upper limit on service pressure is generally imposed to reduce wastage of water through leakage and to minimise the risk of damage to consumer appliances connected to the water supply.

Transmission mains and those distribution mains that do not supply directly to consumers may operate at higher pressures than reticulation mains e.g. up to 3500 kPa. However, pressure should not exceed 22 m head at the ferrule point.

Where a transmission or distribution main supplies directly to the reticulation system, the maximum allowable operating pressure is set by the maximum service pressure.

2.3.3.3 Minimum service pressure

A lower limit on service pressure is usually specified to provide sufficient pressure for the design flow to be delivered onto properties. This includes an allowance for overcoming the basic head losses in the water service, associated fittings, meters and backflow prevention devices.

An additional desirable minimum head for industrial / commercial area shall be included to allow for the likely requirement to install (high-head loss) backflow prevention devices on these properties' services and to provide some allowance for greater water service head losses in these generally larger properties. Where service pressure limits are not specified, the minimum allowable service pressure can be 6m head for reticulation mains.

2.3.4 Pressure variation analysis

A surge analysis of the system shall be undertaken for zones affected by pressure variations e.g. pumped mains, locations affected by control valves, downstream of pressure reducing valves, and where required by the relevant Water Authority. The system shall be analysed for the full range of anticipated rates of change of flow in order to determine the magnitude and frequency of the surge pressure in the system

The service providers in consultation with the Water Authority shall specify whether a surge analysis is required in functional design requirements.

2.4 Water Quality

2.4.1 General

The network configuration shall consider factors that influence the water quality at each customer's property. A water quality report in line with the standards specified by the Sierra Leone Standards Bureau should be published by utilities at a frequency approved by the relevant Water Authority. Aspects for consideration include, but are not limited to:

- a) Prevention of back siphonage.
- b) Water age.
- c) Disinfection.
- d) Seal coating of cement mortar linings

2.4.2 Prevention of back siphonage

The principal method of prevention of back siphonage is to maintain a minimum positive pressure in the system at all times.

Drinking water supply systems shall be designed and equipped to prevent back siphonage. The minimum allowable pressure shall be specified by the relevant Water Authority to meet operational and licence compliance requirements.

2.4.3 Water age

Drinking water supply systems shall be designed to optimise water age in the system, to prevent unacceptable deterioration of water quality. The following arrangements to reduce water age in the system shall be incorporated as applicable into the Design Drawings:

- a) Mains with permanent ends to be avoided by the provision of link mains or looped mains. Particular care shall be taken at the boundaries between supply zones, where the dead-end length shall be minimised.
- b) Mains for short runs to be reduced in size e.g. in cul-de-sacs
- c) Provision of large diameter main capacity to be staged by the initial provision of a smaller diameter main, followed by additional mains as the demand increases.
- d) Staging of the provision of reservoir storage and/or setting operating levels to initially utilise only a portion of the available storage with different settings, if required, for summer and winter.

2.4.4 Disinfection

If disinfection plants and cleaning of the reservoir are required as part of the distribution / reticulation system, they shall be located so as to ensure an adequate cleaning operations and disinfection contact time and adequate chlorine residual prior to water delivery to properties.

2.5 Service Reservoirs

2.5.1 Storage capacity

Service reservoir storage capacity and materials shall consist of operating storage and reserve storage. Operating storage shall cater for demands exceeding the maximum available inflow rate. Reserve storage shall cater for system component failure. Reserve storage capacity shall be determined from a risk assessment study of the supply zone / system, which considers characteristics of the zone / system to determine the risk (consequences and frequency) to water supply continuity and pressure in the event of a system component failure.

The following factors shall be addressed in determining the minimum service reservoir storage capacity and materials required for a system:

- a) Life cycle cost.
- b) Water quality (inlet / outlet pipework configuration, operational detention time, mechanical mixing, disinfection residual detention time, etc.).
- c) Operating storage capacity versus pumping station or supply capacity.
- d) Reserve storage capacity needed to enable emergency maintenance work to be carried out on the supply system.
- e) Availability of emergency supply from adjacent systems (*desirable*).
- f) Ratio of estimated long term demands to short term demands (more economical to provide initial storage with provision for additional storage).
- g) Reservoir site aspects (*space limitations*).
- h) Rainy and dry seasons operational requirements of the reservoir.

Typically, reserve storage capacity should be taken to be equal to 1/3 peak day demand.

Typical storage capacities provided are as follows:

- a) Surface reservoir: Usable reservoir capacity (including reserve storage capacity should be equal to a minimum of 8- 24 h consumption at peak day demand, depending on the needs of the specific system. No net depletion of the operating capacity over the system design period is permitted e.g. where the design period is one day, no net depletion of the operating capacity over maximum day 24 hour period is permitted. The reservoir should be located at an elevation such that the level at the top of the reserve storage (RSL) provides not less than the desirable residual pressure (head) at the customers' services under peak demand conditions
- b) Elevated and standpipe reservoirs: Elevated reservoirs are normally used only for very small pumped supply systems. The capacity provided (including reserve storage) is usually limited to 0.5 to 2 times the peak hour demand because of the high capital costs. The sizing should be balanced against the objective of limiting the number of pump starts per hour during average day conditions

2.6 Future System Expansion

Water mains shall be planned with sufficient capacity to cater for all existing and predicted development within the area to be served. The Planner shall make allowance for existing and future land use zonings and possible rates of development. A defect liability period for system sustainability shall be provided. This must be reasonable enough to match cost of investment.

The water demand allowance in the design for large tracts of vacant land may be determined on the basis of either:

- a) population targets; or
- b) the area to be serviced; or
- c) the number of planned individual properties.

Adjustment may be required to cater for the known performance (demand-based flows) of the existing parts of the water system.

Future demands are estimated on the basis of;

- a) growth forecasts from planning authorities;
- b) the rate of development in recent years;
- c) current town planning zonings; and

- d) discussion with the municipal council on development expectations.

2.7 System Review

System review shall be conducted during the planning and design phases with the level of detail increasing as the design progresses.

Once the system has been planned and layout established, a network analysis shall be conducted to demonstrate compliance with at least the following issues:

- a) Storage and pumping capacity meet demand requirements.
- b) Zones are suitable for maintaining adequate water supply to all existing and future customers (unless this is part of a future augmentation project).
- c) Stop (dividing and isolating) and control valves are positioned to give required control of the system and to provide an alternative means of supply when a distribution main is taken out of service.
- d) Appropriate surge control devices have been specified.
- e) Minimum allowable service pressures will be maintained or exceeded in each zone during a peak day event and maximum allowable service pressures will not be exceeded during low demand periods.
- f) Minimum and maximum allowable service pressures will not be exceeded in each zone.
- g) Disinfection residuals in the system meet Water Authority requirements.
- h) The required water quality infrastructure and/or operational measures have been identified.
- i) Minimum and maximum flows and velocities meet Water Authority requirements.
- j) Pipe and fitting materials are suitable for application and environment.
- k) Potential for future water quality problems or water stagnation is minimised at the various stages of development or as an inherent consequence of the design.
- l) Valve spacing and positioning allows isolation of individual zones.
- m) Mains layout and alignment meets water supply requirements.
- n) Minimum firefighting demands are addressed.
- o) post chlorination

3. HYDRAULIC CONCEPTS AND PRESSURE CLASS

3.1 Sizing

3.1.1 General

Reticulation Mains shall be sized in accordance with this Section.

The system design shall ensure that pressures are maintained within safe limit.

3.1.2 Minimum pipe sizes for reticulation mains

Minimum pipe sizes shall comply with:

ISO 4427 -1&2 (Plastic piping system for water supply and drainage and sewerage under pressure – Polyethylene (PE)

ISO 4439:1979 Unplasticized polyvinyl Chloride (PVC) pipes and fittings – Determination and specification of density.

ISO 2531:2009 Ductile Iron pipes, fittings, accessories and their joints for water applications

In Table 2 and Table 3 minimum pipe diameters for **reticulation mains** have been established to ensure adequate flow rates and residual pressures.

Table 2: MINIMUM PIPE SIZES FOR NEW DEVELOPMENTS

Development	Minimum Pipe Size (DN)		
	PVC-U	Polyethylene (PE)	Steel Pipes
Low and medium density residential	100	150	200
High density residential (≥ 6 storeys)	150	200	250
Multiple developments of high density residential (≥ 12 storeys)	200	250 or 300	300/450
Industrial and commercial	150	200	300/450

NOTES:

The Water Regulator or relevant authority may authorise smaller pipe sizes to address issues such as water quality in cul-de-sacs, provided sufficient capacity for future demand, provided that requirements for firefighting supply are otherwise met.

Table 3: MINIMUM PIPE SIZES FOR EXISTING DEVELOPMENTS

Development	Minimum Pipe Size (DN)		
	PVC-U	Polyethylene (PE)	Steel Pipes
Low and medium density residential	100	150	200
High density residential (≥ 6 storeys)	150 (If the current one is 100mm and has sufficient hydraulic future capacity for the proposed development then 100mm can be used until the capacity is reached)	200 (If the current one is 125mm and has sufficient hydraulic future capacity for the proposed development then 100mm can be used until the capacity is reached)	250
Multiple developments of high density residential (≥ 12 storeys)	200 or 225 (If the current one is 100mm or 150mm and has sufficient hydraulic future capacity for the proposed development then 100mm or 150mm can be used until the capacity is reached)	200 or 300 (If the current one is 125mm or 180mm and has sufficient hydraulic future capacity for the proposed development then 125mm or 180mm can be used until the capacity is reached)	300/450

NOTES:

The Water Regulator or relevant Authority may authorise smaller pipe sizes to address issues such as water quality in cul-de-sacs, provided sufficient capacity for future demand, provided that requirements for firefighting supply are otherwise met.

3.1.4 Fire flows

Where a specific firefighting allowance is required, the relevant Water Authority in consultation with the National Fire Force shall specify design requirements.

Where the local planning authority identifies an abnormal potential demand for water for firefighting purposes, the Designer, with the agreement of the relevant Water Authority, shall notify the relevant fire authority of the need to identify alternative emergency water supply sources.

3.1.5 Sizing by analysis

3.1.5.1 General

The relevant Water Authority may determine the sizing of the larger size water mains, in which case the following is provided for information purposes only.

Pipework design formulas and network analysis, nominated by or acceptable to the Water Designer, shall be used to select the required pipe sizes. Hydraulic design shall be based on the forecast demand, the acceptable velocity range, allowable head loss and the acceptable pressure range.

3.1.5.2 Head losses

The indicative criterion for economic design is based on velocity.

The following head losses may also be used as a guide to improve the size of water mains by reducing the head loss, for accurate head-loss the designer to calculate using formulas:

- a) 5 m head/km for \leq DN 150 (PVC-U) or \leq DN 180 (Polyethylene).
- b) 3 m head/km for \geq DN 200 (PVC-U) or \geq DN 250 (Polyethylene).

Head loss shall be calculated using computer models or hydraulic formulas.

Hydraulic design methodology shall be approved by the relevant Water Authority. The values in sub-clauses (a) and (b) are guidelines only for sizing mains to carry peak system demands.

3.1.5.3 Hydraulic roughness values

The roughness value k_s considered in the hydraulic analysis shall be either:

- a) design roughness value k_{s1} which includes influences of straight pipes without fittings;
or
- b) design roughness value k_{s2} which includes influences of straight pipes with an allowance for fittings and valves.

If k_{s1} is used, secondary head losses shall be considered. Possible long-term increase of roughness shall be considered in establishing the design roughness value. Head losses from components such as meters and pumps shall be considered separately.

3.1.5.4 Flow velocities

The design shall ensure that acceptable flow velocities are achieved within the supply network.

Sizing of all mains (including, transfer, distribution, transmission / trunk, reticulation, service and suction mains) shall be based on a sound compromise between capital and operating costs.

For pumping station suction and delivery velocities, refer to Table 10.

As a guide to avoid uneconomical head losses, flow velocities in the reticulation network should generally not exceed 2.0 m/s for an hour period in any day or maybe determined according to ISO 3354:2008.

In certain circumstances, such as with flows required for firefighting, velocities up to 4.0 m/s may be acceptable or maybe determined according to ISO 3354:2008.

High velocities are used as an indicator of potential problems such as low pressures.

The design shall also ensure adequate minimum velocities for maintaining water quality to the relevant Water Authority's requirements, typically assessed at average day demands.

The optimum velocity is typically in the range 0.8 m/s to 1.4 m/s.

The following factors shall be considered in determining flow velocity:

- a) Water age (travel time through the system).
- b) Turbidity.
- c) Pressure.
- d) Surge.
- e) Pumping facilities.
- f) Pressure reducing devices.
- g) Pipe lining materials.

Additional factors to be considered includes:

1. Topography
2. Distance of the reservoir

- 3. Number of users
 - 4. Pump efficiency & durability
 - 5. Water sources (Availability of water)
- h) Leakages (Water loss)

The total travel time, including retention time within the system (water age) from the last disinfection facility should be less than 72 h under all demand conditions (i.e. to maintain chlorine residuals at an effective level).

Where, on the basis of average day demand, a proposed system configuration will result in a water age of more than 48 h, the relevant Water Authority shall be consulted on alternative options before proceeding with the design.

3.2 Design Pressures

3.2.1 General

For gravity systems, the system design pressure (nominally static pressure) shall be established and documented in accordance with the relevant ISO

For systems subjected to system surge (generally pumped), the system design pressure shall be established and documented in accordance with the relevant ISO

Design pressures, based on pressures likely to be experienced by components of a system, including some allowance for abnormal operating situations, and shall be used for the selection of:

- a) Materials and pressure classes (PN) for pipes and fittings.
- b) Appropriate surge control devices.
- c) System test pressures.
- d) Thrust and anchor block design.

For reticulation mains, where it can be shown that the system design pressure is ≤ 90 mH, a default design pressure of 112.5 mH may be authorised, by the Water Authority, for use in design of thrust and anchor blocks. Similarly, the system test pressure authorised for use may be 112.5 mH. For a greater system design pressure, proportionately greater pressures, for design of thrust and anchor blocks and for system test pressure, shall be used (see Table 4).

Table 4: TEST AND ASSET DESIGN PRESSURES – BASED ON SYSTEM PRESSURE

System Pressure - mH	Test Pressure (Min. 1.25 x System Pressure)	Asset Design Pressure (Not less than test pressure) mH
≤ 90	112.5	112.5
From 90 to 112.5	From 112.5 to 140.6	From 112.5 to 140.6
112.5	Up to 140.6	Up to 140.6

For distribution, transmission and transfer mains, relevant Water Authority may authorise lower limits than 112.5 mH for design pressure on an individual project basis.

Any potential adverse impacts in respect of customer service requirements, potential system leakage and infrastructure maintenance costs shall also be addressed.

3.2.2 Gravity systems

Design pressure of a gravity system is deemed to be the maximum static pressure in the system, calculated as the full supply level of the supply reservoir (tank) minus the lowest ground level along the route of the system water mains. The relevant Water Authority may also

require an arbitrary allowance to be added to a system's calculated design pressure based on individual project's requirements.

Hydraulic design of a pressure-boosted sub-system of a gravity system shall be undertaken in accordance with Clause 3.6 and Section 6.

3.2.3 Systems subjected to dynamic pressures

For systems subjected to systemic surge (generally pumped), the pressure magnitude i.e. the difference between the minimum and maximum cyclic pressures and the estimated lifetime number of pressure cycles shall be established and design undertaken in accordance with Clause 3.6.

The maximum pressure to be used in the design for dynamic stresses (Clause 3.6) or for use as the design pressure for other aspects of system design (as per Clause 3.2.1) can be determined in a number of ways, typically:

- a) Pressure due to the no discharge head (NDH) of the pump(s) plus the maximum suction pressure minus the lowest ground level along the route of the pipeline, or
- b) Pressure due to the operating pressure of the pump(s) plus the maximum suction pressure minus the lowest ground level along the route of the pipeline plus an allowance for surge due to the pump(s) starting.

The minimum pressure to be used in the design for dynamic stresses (Clause 3.6) can be determined from:

- a) Pressure due to the minimum suction pressure to the pump(s) minus the lowest ground level along the route of the pipeline.
- b) Pressure determined from an assessment of the negative surge due to pump(s) shutdown minus the lowest ground level along the route of the pipeline.

3.3 Pressure Class of System Components

3.3.1 Gravity systems

For any gravity and pressure reduced systems the pressure rating (PN) of pipes and fittings needs to be more than the design pressure

Typically 25% of allowance to be provided for pipes and fittings in order to combat random surges. The relevant Water Authority may specify an additional allowance depending on the project's requirement.

The required pressure class of system components shall be recorded on the Design Drawings.

3.3.2 Systems subjected to dynamic pressures

For systems subjected to systemic surge, the required pressure class of system components shall be determined in accordance with Clause 3.6.

If a pressure boosting sub system is required within the gravity system then need to make sure all pipework and fittings' PN is more than the pressurised system.

The required pressure class of the system components shall be recorded on the Design Drawings.

3.3.3 Minimum pressure class

The minimum class of all plastics pipes and fittings (i.e. PE & PVC-U) used shall be PN 16 unless specific approval to the contrary is given by the Water Authority for a nominated project.

Ductile iron pipes shall be minimum DN 35 (or flange class, as appropriate), unless specific approval to the contrary is given by the relevant Water Authority. Cement mortar lined ductile iron fittings shall be minimum DN 35.

3.4 Thrust and anchor block design

Thrust blocks shall be designed to withstand the maximum system test pressure (Refer to Clause 3.5).

3.5 System test pressure

The system test pressure applied to each section of a water mains network shall be such that:

- a) At the highest point in the test section the pressure shall be not less than the system design pressure, and
- b) At the lowest point in the test section, the maximum test pressure shall be the greater of:
 - i) times the system design pressure;
 - ii) the relevant Water Authority-specified test pressure, such as 100 or 120 m head.

The required test pressure shall be recorded on the Design Drawings and testing shall be specified to be performed in accordance with the appropriate method.

It is important to note that, due to water mains often being in undulating topography and for the minimum and maximum test pressures to be met, it may be necessary to undertake the testing in a number of test sections to avoid exceeding the maximum allowable operating pressure (MAOP) of pipeline component.

3.6 Design for dynamic stresses

3.6.1 General

The Designer shall provide full details of surge and fatigue analyses, including all calculations, assumptions and referenced documents, where requested by the relevant Water Authority. Design for dynamic stress should be in line with ISO 12162:2009 Thermoplastics materials for pipes and fittings for pressure applications — Classification, designation and design coefficient and

ISO 15853:1999 Thermoplastics materials — Preparation of tubular test pieces for the determination of the hydrostatic strength of materials used for injection moulding

3.6.2 Surge

All transfer and distribution mains (gravity and pumped) and all pumped reticulation systems shall be assessed for dynamic stresses by an appropriate specialist. Suitable preventive measures shall be specified to control surge. The maximum design pressure of these systems shall include an allowance for the estimated magnitude of dynamic stresses.

3.6.3 Fatigue

For pumped systems, the design shall address the potential for fatigue arising from dynamic loading.

Metallic pipes and fittings do not require fatigue analysis; the maximum design pressure may be up to the maximum allowable operating pressure (MAOP) specified in the product standard or nominated by the manufacturer.

3.6.4 Fatigue de-rating of plastics pipes and fittings

Prior to plastics components being specified for mains in a pumped system or system otherwise exposed to regular surge / water hammer, the Designer shall verify suitability by applying the relevant design assessment nominated in Table 5.

Table 5: METHODS FOR DESIGN OF PLASTICS PIPES AND FITTINGS FOR DYNAMIC STRESSES

Pipeline system items	Guideline
PVC pressure pipes	IGN 4-37-02
PE pressure pipes	IGN 4-37-02
PE fusion fittings	IGN 4-37-02

3.7 Temperature De-rating of Plastics Pipes and Fittings

The pressure class of plastics pipes is determined at 20 °C.

For more information refer to ISO 12162:2009, ISO 15853:1999

4. GENERAL DESIGN CONCEPTS AND MAINS

4.1 General Requirements

4.1.1 Design tolerances

The location and levels, where applicable, of the water main shall be determined and specified to the following tolerances:

- a) Horizontal alignment in metres to one decimal place for all mains.
- b) Level:
 - i) Reticulation mains, to meet minimum cover requirements
 - ii) Transfer and distribution mains, in metres to two decimal places.

Horizontal alignment shall be referenced to the relevant Water Authority's preferred coordinate system and, where possible, to local property boundaries. Levels shall be referenced to relevant Sierra Leone height datum. The Ministry of Lands in Sierra Leone considers WGS 84, 28 and 29.

4.1.2 Levels

The designer to provide a longitudinal elevation on the design drawings by considering present / future road, drainage and other services in the vicinity. There should be strong collaboration from the design stage with every authority or institution that are involved in utility or other services

4.1.3 Environmental considerations

4.1.3.1 General

In selecting the water main route, the Designer shall evaluate its impact on the environment for both the construction and operational phases consistent with Sierra Leone's current policies on environmental impacts etc. The relevant Water Authority in consultation with EPA-SL to advise the designer if any such important considerations to be adhered to.

Some typical areas that should be avoided are:

- a) Ensure minimal disturbances, with consultation with the respective authorities, (EPA Ministry of Environmental) environmental safe guards
- b) National parks, nature reserves, proclaimed reserves, state forest, stands of native vegetation, bushland, habitats of threatened native species.
- c) Waterways and flood ways.
- d) Wetlands, swamps, estuaries, sand dunes, foreshore areas.
- e) Land identified as potentially subject to inundation from predicted sea level rise.
- f) Heritage item precincts.
- g) Landfill sites and contaminated land.
- h) Aggressive ground conditions e.g. acid sulphate soils and aggressive ground waters.
- i) Mine subsidence areas (including areas outside Mine Subsidence Board areas).

The following specific environmental protection issues shall be considered during route selection and discussions with Owners / Regulators:

- a) Use of alternative excavation technology such as trenchless techniques: tunnelling, boring directional drilling and micro-tunnelling.
- b) Environmental impacts of de-watering
- c) Environmental impacts of rock excavation.
- d) Type and size of construction equipment.
- e) Steep slopes i.e. generally steeper than 15% grade.
- f) Unstable areas subject to rock falls, mine subsidence areas, slips and flows.
- g) Local deviations around significant flora.
- h) Minimising the area of disturbance.
- i) Season of construction.
- j) Minimising transport of soil borne disease.
- k) Rehabilitation of the construction site post construction.

4.1.3.2 Urban salinity

The Designer shall consult the local planning authority to determine whether urban salinity management strategies are in force and to ensure that appropriate precautionary measures are adopted.

Specialist advice shall be sought to determine impacts on water infrastructure and appropriate protection measures where required.

4.2 Reticulation Design for Water Quality

4.2.1 Layout of water mains

Termination points or dead-ends shall be avoided where necessary to minimise the likelihood of poor water quality and customer complaints. Alternative configurations such as a continuous network, link mains, looped mains and use of reduced sized reticulation mains shall be incorporated into reticulation layouts to maintain water quality wherever practicable.

4.3 Water Main Access

Access into water mains shall be provided for water mains \geq DN 600. The access facility shall be 600 mm diameter clear openings located at 1 km maximum spacing

The locations of person-access facilities shall be shown on As-built Drawings and or Work As Constructed drawings.

4.4 Location of Water Mains

4.4.1 General

Water mains should be located in the road reserve.

The location shall be:

- a) as specified by the relevant Water Authority in consultation with SLRA;
- b) in accordance with the road reserve space allocation agreement or as nominated in the local agreement with the road owner and other utility service providers; and
- c) in accordance with any other applicable statutory requirements.

Alignment of mains shall be compatible with Standard Code of Design. The Designer shall optimise the system configuration and the Concept Plan.

Water mains shall be:

- a) aligned parallel to property boundaries or road features e.g. kerbs;
- b) located to maintain adequate clearance from structures and other infrastructure; and
- c) Located to allow unhindered access for repairs and maintenance.

Other aspects shall be considered during the route and alignment selection including:

- a) Identification of topographical and environmental issues.
- b) Special foundation or geotechnical requirements.
- c) Need for easements (if required by the relevant Water Authority).
- d) Avoidance of dead-ends.
- e) Mains running parallel to railway / tram lines / high voltage transmission lines, which may require protection from stray current corrosion if metallic
- f) Avoidance of placement of mains on the fill sides of roads and PUAs.

4.4.2 Water mains in road reserves

4.4.2.1 General

For mains located in road reserves, the following design requirements shall be evaluated and incorporated wherever practicable:

- a) Mains shall be in the least costly location such as on the side of the road reserve that serves the most properties and minimises the length of property services.

- b) Where roads are cut into the hillside, mains shall be on the cut or high side to best utilise road drainage and limit the risk of consequential damage from pipe failure.
- c) Excavation for the water main shall be in undisturbed ground.
- d) The balance between initial capital cost and operational and maintenance costs shall be determined to provide the lowest life cycle cost to the relevant Water Authority
- e) Obstructions along the water main route shall be identified.
- f) Clearances from other utility services, such as electricity and telecommunication cables, gas mains, stormwater drains and sewers shall be specified.
- g) Known future utility services and road widening shall be accommodated.
- h) Mains shall be located to minimise potential long-term maintenance problems arising from local authority / road Owner landscaping and tree planting policies and proposals.
- i) Locate the main to suit the provision of proposed future mains.

4.4.2.2 Location in footway

Agreements to facilitate the allocation of space within various sized footways to the major users of that space may be applicable. The relevant Water Authority to specify the relevant requirement to the designers.

Where possible, a water main shall be located on the side of the street that is opposite the location of power cables.

Wherever practicable, water mains shall be laid on the opposite side of the road to the sewer. As the sewer is usually laid on the high side, the water main, in such cases, will be laid on the low side.

4.4.2.3 Location in carriageway

If there is no space available in the footway, the water main shall be located in the carriageway. The kerbside lane is the preferred location within the carriageway, so as to minimise interference with traffic during construction and future maintenance. The relevant Water Authority to advise to the designers of their relevant requirements.

Mains shall not be located in motorway reserves unless written approval is obtained from the relevant road Owner/authority and the relevant Water Authority.

Where located in major roads and/or in major intersections with other roads, water mains shall be installed with at least the minimum cover of 600 mm.

4.4.2.4 Location in roundabouts and Laybys

Where applicable, a main shall be laid in a straight line through roundabout intersections and bus bays, as a prolongation of the line of the main leading to the intersection.

Where a straight-line location of the main is not feasible, the relevant Water Authority shall be consulted concerning alternative arrangements for the main, e.g. deviation around the intersection.

Surface fittings (e.g. valves and hydrants) shall be located in footways clear of the roundabout intersection or bus bay.

Preference is for surface ancillaries (e.g. footpaths, bikeways, bus shelters, benches etc) not to be placed over water infrastructure.

4.4.3 Location in other than dedicated public road reserves

Where no suitable location is available in an existing or proposed dedicated public road reserve, consideration shall be given to alternative locations such as state land/reserves or within an easement in private properties.

Where the water main is located on private property, written approval of the landowner is required and an easement or land tenure shall be provided.

4.4.4 Effect on vegetation

Vegetation shall not be removed unnecessarily, particularly mature and sound stands of trees. Removal of dead trees, either fallen or standing, shall also be avoided as they may provide a natural habitat for native fauna.

4.4.5 Water mains near trees

Trees located along the proposed route of the water main shall be identified for protection and details, including a record of their health, stability and importance, shall be documented. Specialist advice shall be sought as a permit may be required for tree removal and the cost and constraints of such action may be a design consideration.

4.4.6 Crossings

4.4.6.1 General

Water main crossings of roads, railway lines, water courses, underground services and other obstructions shall be designed to the most appropriate alignment to minimise:

- a) the likelihood of failure of the main in the crossing e.g. increasing the PN rating of the pipe to take account of any surface damage during installation;
- b) the likelihood of future 3rd party interference e.g. ensuring the specified minimum clearances between the main and other services are achieved;
- c) the likelihood of conflict with underground structures or foundations e.g. ensuring a suitable clearance is achieved;
- d) the number of joints and surface fittings within the crossing;
- e) the likelihood of leakage of joints;

- f) restoration of improvements (generally surface) in the crossing; and
- g) the likelihood of other factors that limit future asset management treatments for the main, e.g. condition assessment, leakage detection, pressure management, replacement, renewal, rehabilitation etc.

The crossing shall be at 90° to the road, service, etc. if practicable

Where the Designer considers that a water main may require additional mechanical protection against external factors, e.g. external loading, third-party intrusion etc. such protection shall be provided.

4.4.6.2 Requirements for encased pipe installations

The encasing pipe shall be capable of withstanding all installation (e.g. jacking, grouting etc.) and post installation loads (e.g. soil overburden, groundwater, traffic, rail, etc.).

The Water Authority approval is necessary in selecting relevant encasing pipework.

The encasing pipe shall be either:

- a) RC (Reinforced Concrete); or
- b) Bare steel; or
- c) GRP (Glass Fibre Reinforced Plastics); or
- d) VC (Vitrified Clay)

NOTE: GRP pipes come in two types: (a) Filament Wound (FW) and (b) Centrifugally Cast (CC). The relevant Water Authority will approve the type of GRP pipe appropriate for a particular application.

The diameter of the bored hole should not exceed the outside diameter of the encasing pipe by more than 100 mm. Where the diameter of the bored hole exceeds the outside diameter of the pipe by more than 50 mm, the annulus shall be promptly grouted.

The water main shall be located within the encasing pipe so as to achieve a minimum grade of 0.1%.

Where fully welded pipes such as steel or PE are installed in encasing pipes, sufficient annulus dimension shall be specified so that the main can be secured in place using hardwood skids or a proprietary centralising and spacer system. The annulus shall be grouted.

The specification shall require that the installed section of encased pipe shall be separately pressure tested before grouting and connection to the water main.

4.4.7 Railway reserves

Water mains shall not be laid within railway reserves unless it is absolutely necessary, in which case the crossing shall be authorised by the relevant Railway Authority in writing.

Crossings shall be made as close as practicable to 90° to the railway reserve. *The water main may require mechanical or cathodic protection or both.*

A typical railway crossing drawing is shown in Figure 2 for information:

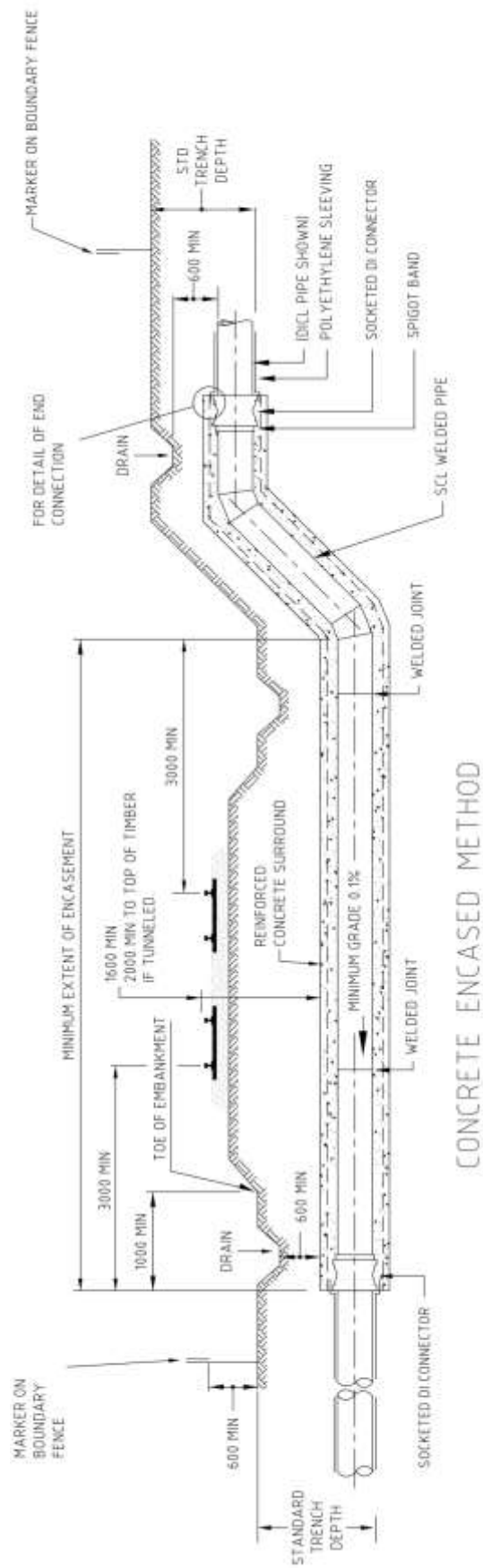

Figure 2: TYPICAL ROADWAY/RAILWAY CROSSING

4.4.8 Crossings of creeks or drainage reserves

The Design Drawings and/or Specification shall nominate the means for crossing of creeks and drainage reserves, as well as the alignment, mechanical protection (e.g. encasing pipe or concrete encasement) and construction details.

The crossing shall be $90\pm 15^\circ$ to the creek or drainage reserve except where otherwise approved by the Water Authority.

4.4.9 Overhead power lines and transmission towers

Overhead power lines are a hazard for trenching and mechanical handling of pipes. Inducted currents in the water main may be a safety hazard or induce corrosion. Water mains shall be located as far as practicable away from overhead power lines and transmission towers.

Investigations shall also be carried out, to determine potential safety risks where:

- a) welded steel pipelines simultaneously run parallel and close to high voltage power lines i.e. for more than 1 km parallel and within 500 m of power lines >50 kV;
- b) metal pipelines are located within 5 m of a transmission tower; or
- c) metal pipeline access is within 50 m of a transmission tower.

NOTE: The above distances are indicative only.

4.4.10 Marking tape

4.4.10.1 General

Non-detectable marking tapes provide a warning to excavators and minimise the likelihood of damage to the pipeline including any protective sleeving. Detectable marking tapes also enable the pipeline to be detected from the surface prior to excavation.

The detection ability of detectors is a function of earthing, ground moisture, ground mineralisation and the proximity of other metallic objects/services in the vicinity of the detectable tape. The induction clamp and direct connection detection methods allow tape detection at much greater distances between the detector and the tape than the induction detection method.

Marking tapes are also used to identify special features of the pipeline such as where restrained joint systems are used.

4.4.10.2 Mains

All water mains constructed using open-cut trenching shall be installed with marking tape laid on top of the embedment zone.

Detectable marking tape shall be specified for installation above all buried non-metallic water mains, where there is no fixed reference point for easy location of the pipe such as kerbs etc. Non-detectable marking tape shall be specified for all other applications where the water main can be easily located with fixed reference points.

Detectable marking tape shall also be specified for buried metallic mains where installed deeper than specified maximum depths of cover.

4.4.10.3 Property services

It is preferred that all new property services \leq DN (DN25 and 50) shall be installed using PE pipe (pvc, upvc/gi, etc).

Marking tape shall be specified for all PE property services to the water main.

4.5 Rider Mains

The design shall identify the need for rider mains and shall detail their alignment and connection details in the Design Drawings.

A rider main may be required where a distribution main is or will be laid in the street. A separate main i.e. a rider main, cross connected to the distribution main, is provided for service connections.

Hydrants, where necessary on the distribution main and/or rider main, shall be provided

4.6 Connection of new mains to existing mains

All works on the existing reticulation system shall be considered as “live works” and will be controlled by the Water Authority or their designated agent. These works shall be clearly delineated on the Design Drawings and shown in sufficient detail such that the works can be readily constructed.

If the proposed main crosses a roadway adjacent to the connection point, the full length of main at the road crossing shall be included in the “live works”.

The connection point to the existing system shall be located to minimise disruption of supply to customers and be subject to the Water Authority approval.

The following drawings depicts some guidance of providing connections, under pressure connection is preferred when disruption of service is cannot be eliminated. Cut-in connection method would be the most preferred method

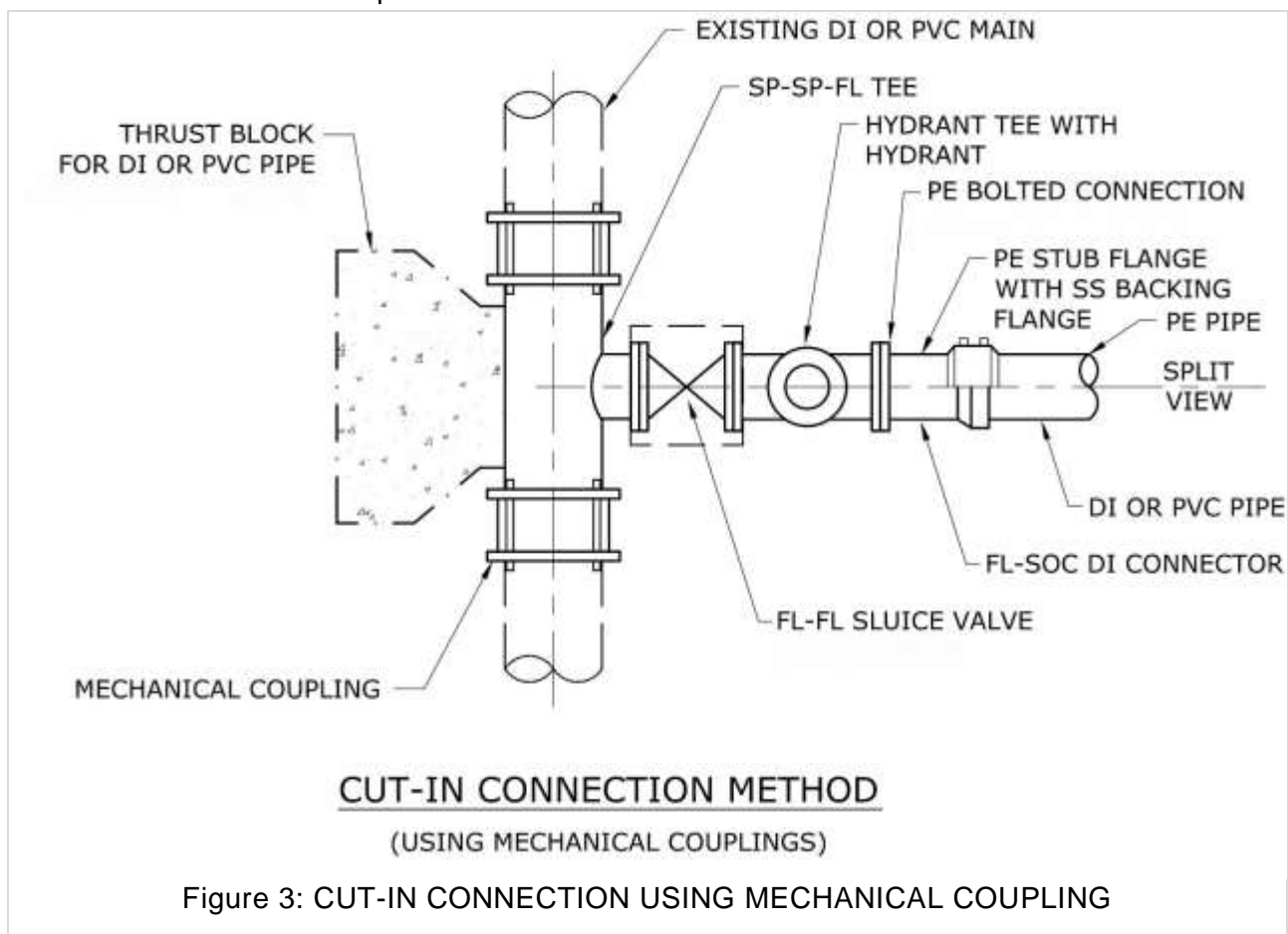

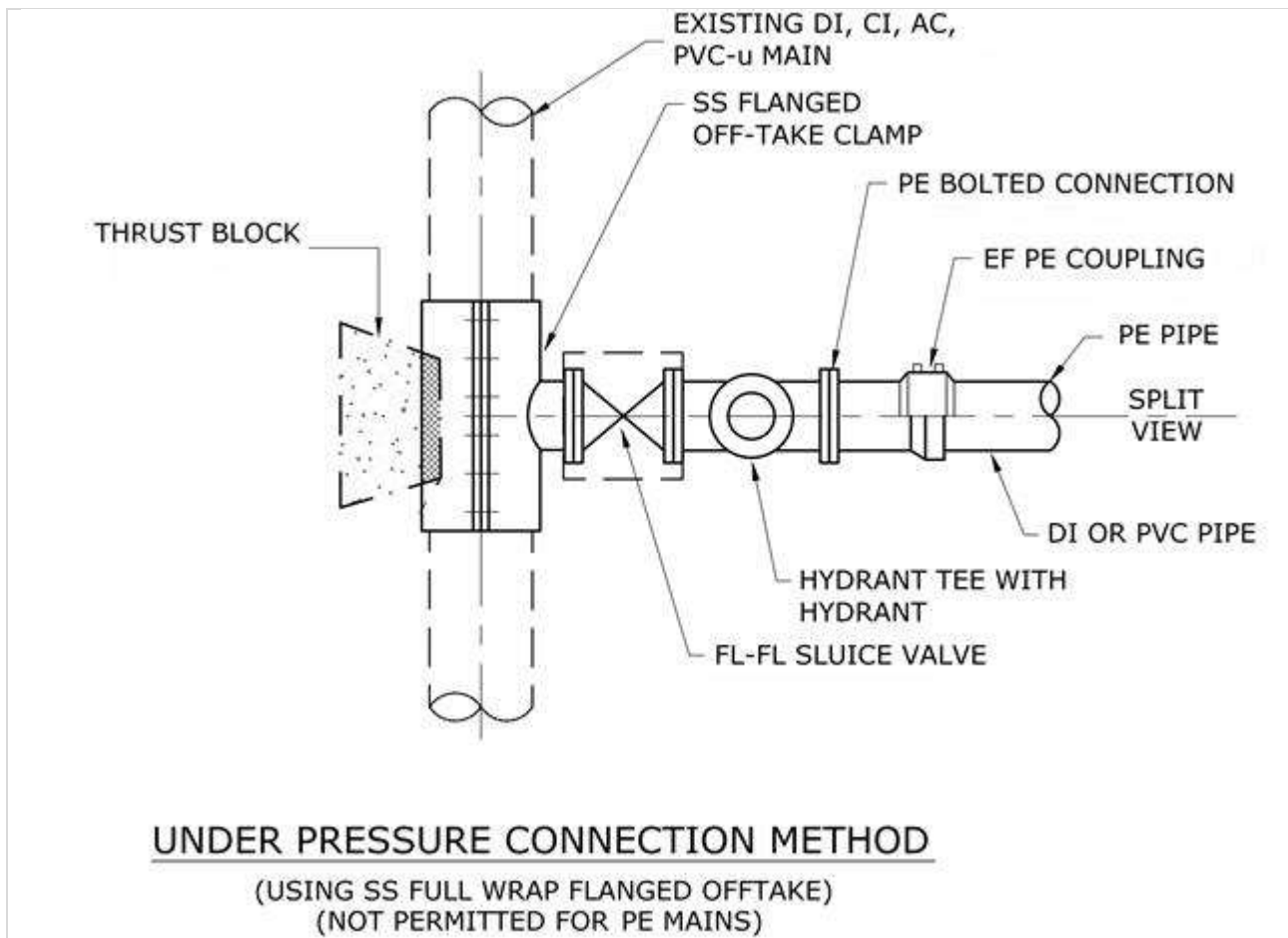

Figure 4: UNDER PRESSURE CONNECTION METHOD

4.7 Termination Points

4.7.1 Permanent ends of water mains

Where a dead-end has been authorised by the Water Authority, the main shall be laid to a point no more than 2 m past the required location for the property service connection of the last property served.

A suitably anchored flushing bend or flushing assembly at the end of the water main shall be provided

4.7.2 Temporary ends of water mains

Where it is necessary to provide a temporary dead-end as part of staged servicing, the water main shall be laid to a point, defined by Water Authority, adjacent to the boundary of a subdivision.

In order to eliminate shut-offs and disruption of services to existing customers, the main shall be terminated-

4.7.3 Chlorination assemblies

A chlorination assembly shall be provided at all termination points on mains DN 250 and larger.

This assembly will normally act as the swab control discharge. A pilot point (chlorination injection point) may be required for mains in some cases where there is no hydrant adjacent to a valve at the point of supply.

The design shall include the following:

- a) location of the chlorination injection point;
- b) location of the swabs; and
- c) pitot points

Hydrants and/or test points may be used as chlorination assemblies.

4.7.4 Flushing points

Drinking water reticulation systems shall be capable of being flushed for operational and water quality purposes. Mains shall be provided with points of flushing at maximum intervals nominated by the Water Authority and at the end of reduced sized mains in cul-de-sacs.

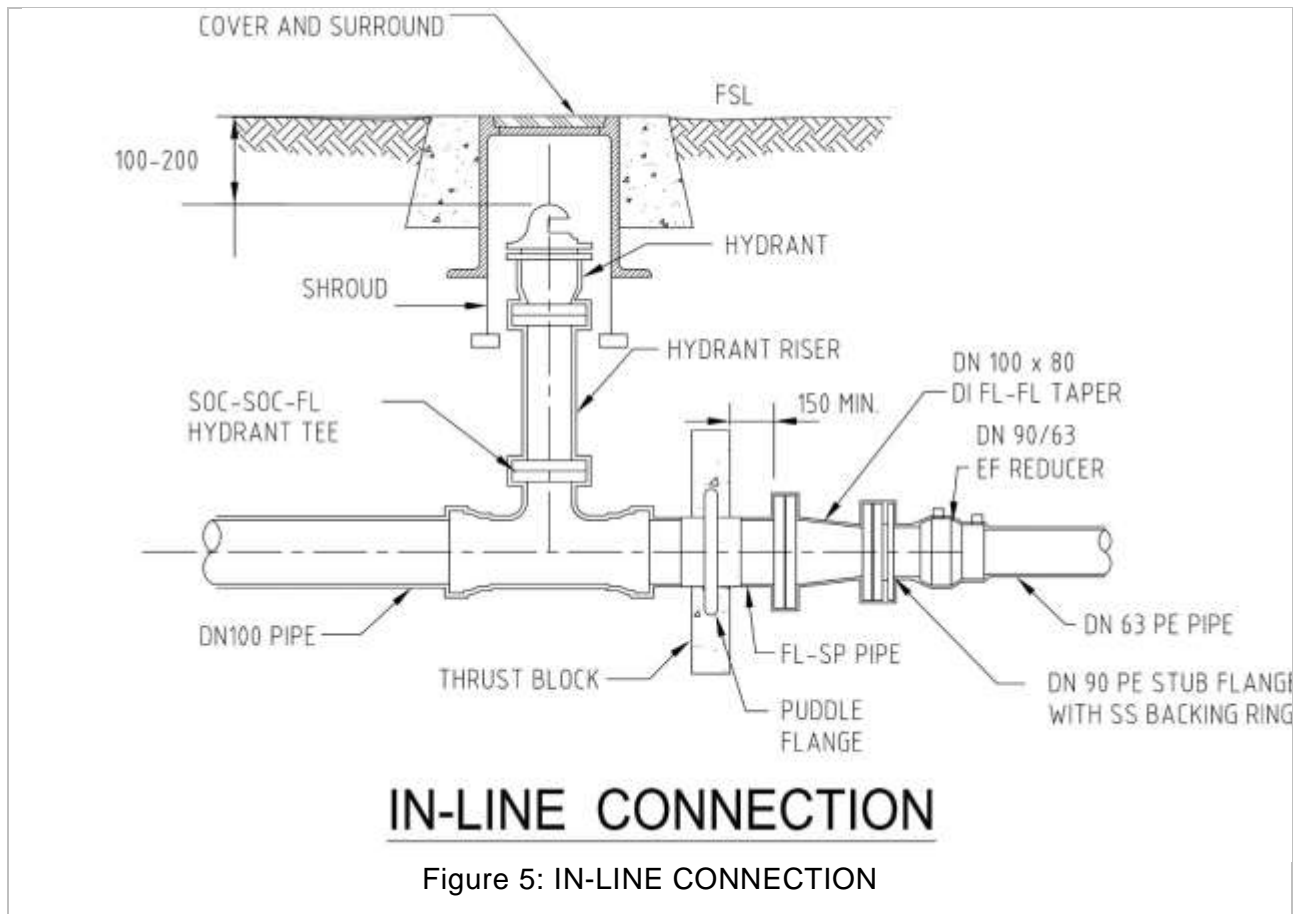

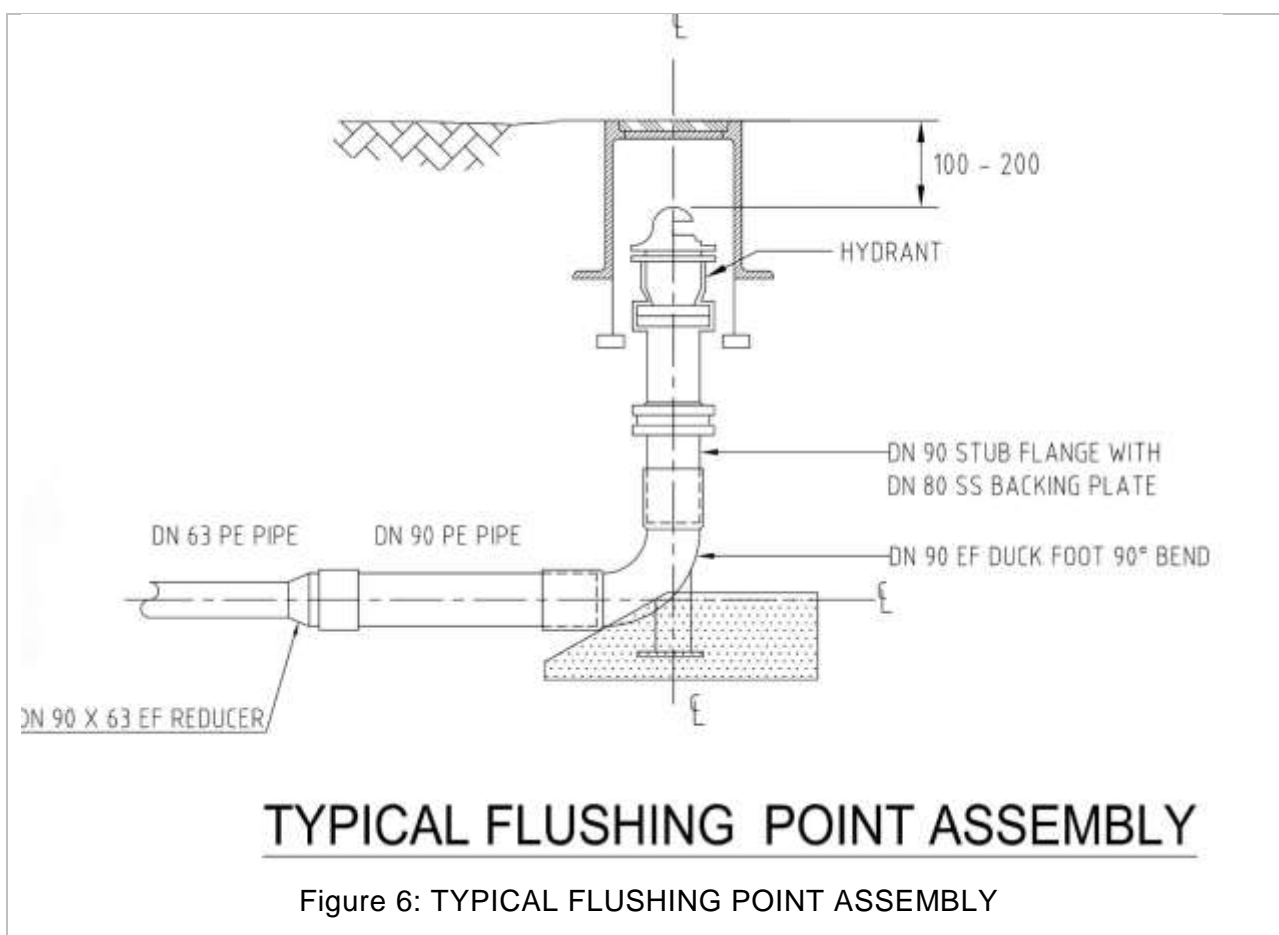

4.8 Property Services

4.8.1 General

The Design Drawings shall provide property service layouts, service arrangements and sizes (pipes, fittings and ball valves), connection (tapping) arrangements, methods and sizes for single and split services located in footways and across road carriageways, including service duct details and kerb marking, and above-ground and below-ground meter layouts and arrangements as required.

Some typical drawings are shown below for information, the designer to show these based on the best practice available in Sierra Leone in conjunction and approval with the Water Authority.

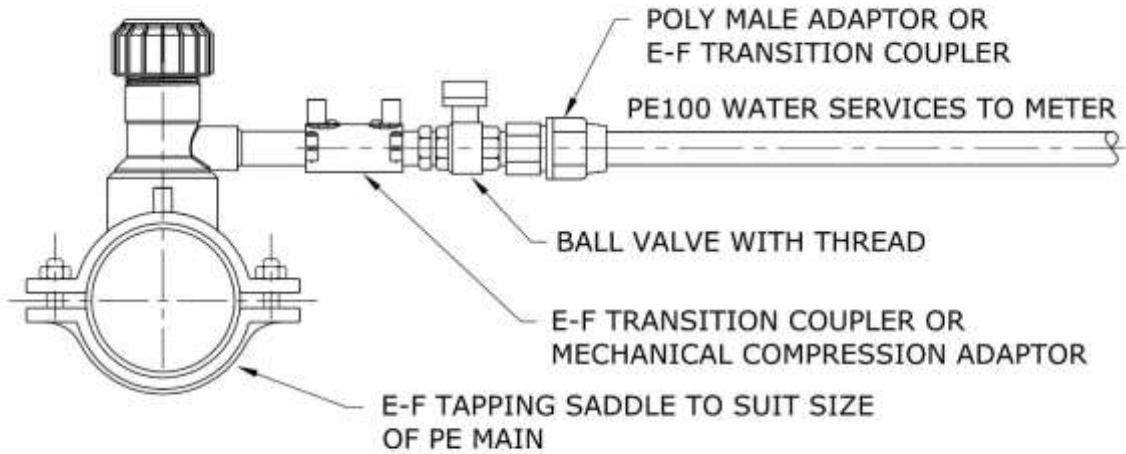

E-F SADDLE DETAILS

Figure 7: ELECTROFUSION (EF) SADDLE DETAILS

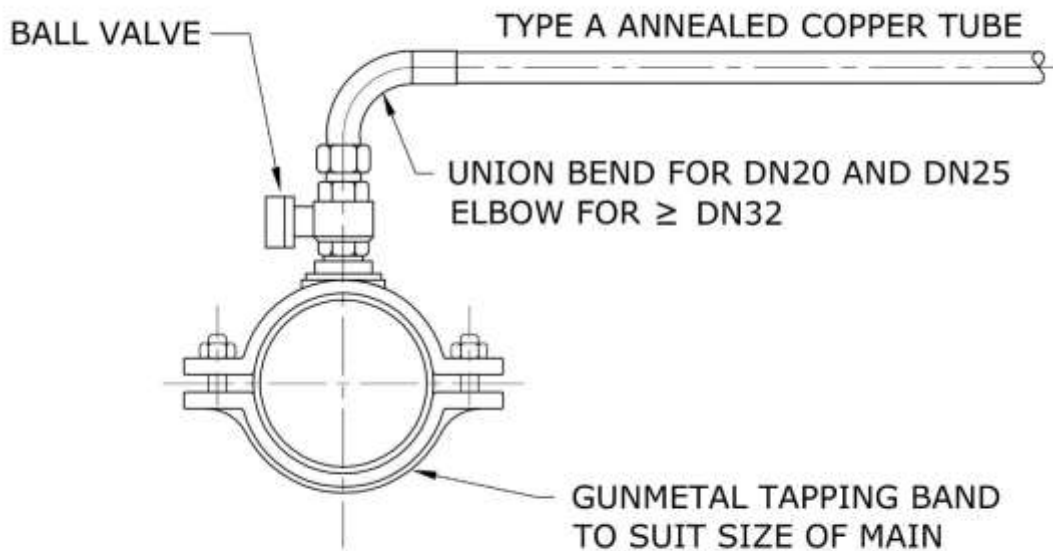

TAPPING BAND ARRANGEMENT

Figure 8: TAPPING BAND ARRANGEMENT

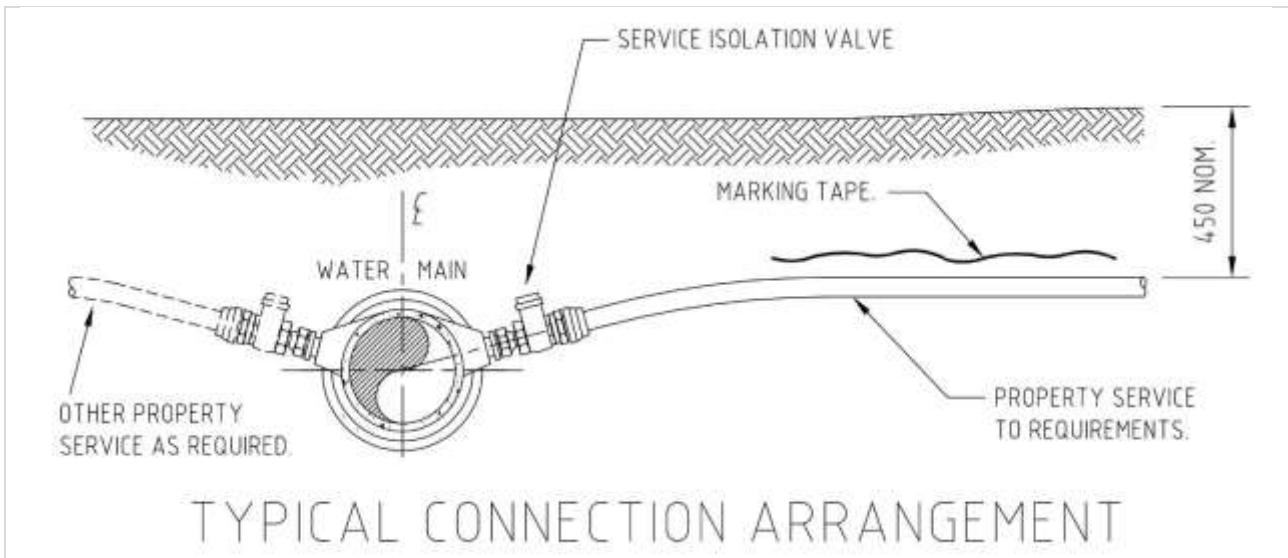

Figure 9: TYPICAL PROPERTY SERVICE CONNECTION

4.8.2 Connections to water mains

Connections for property services shall only be installed on drinking water reticulation mains (including rider mains) within the size ranges permitted by the utility in consultation with the Water Authority.

4.8.3 Services, Outlets and Water Meters

Property services for drinking water servicing new residential lots shall be specified for installation using colour-coded PE pipe, ductile iron and steel pipes. Property services for existing lots (water main renewals) may be PE or ductile iron and steel pipes. Property services shall be positioned to suit the type of planned development.

Kerb markers shall be provided to indicate the location of property services that cross roadways. Service duct markers shall be provided on the kerb to indicate the location of the service duct containing drinking water services.

These markers to be based on the current practice in Sierra Leone and in consultation with the relevant Water Authority.

Some typical drawings are shown below for information, relevant drawings to be shown in design drawings by the designer.

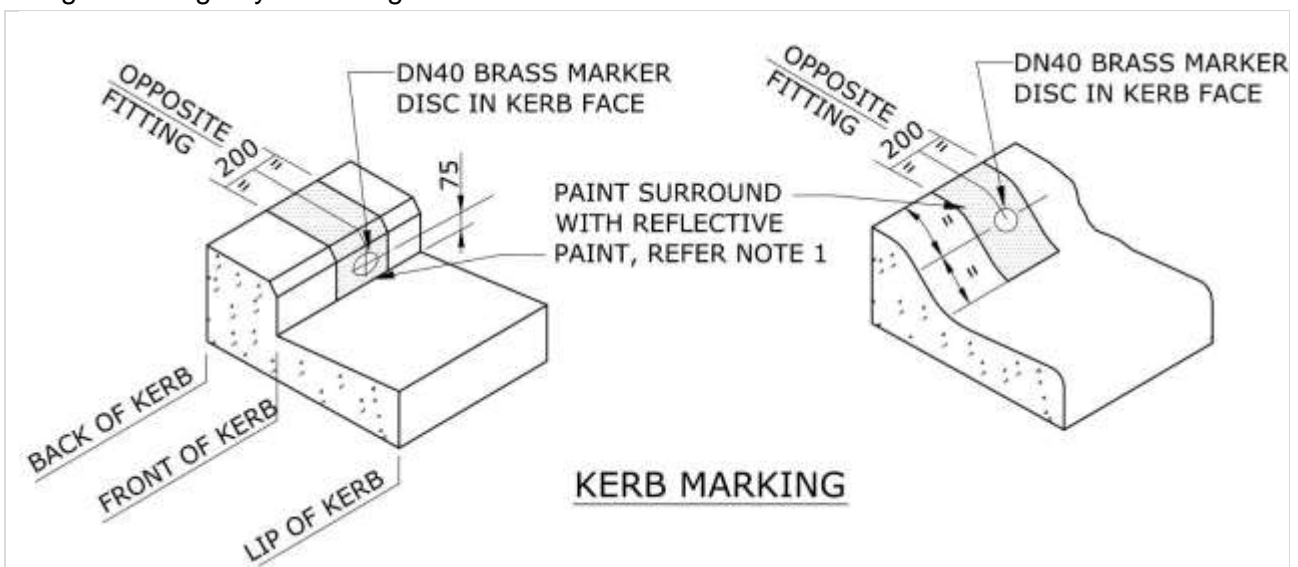

Figure 10: KERB MARKING

4.9 Obstructions and Clearances

4.9.1 General

All underground obstructions and services, surface obstructions and structures along the route of the proposed water main shall be determined and shown on the Design Drawings.

4.9.2 Surface obstructions

Surface obstructions shall be located during the initial survey and inspection of the site and through enquiries to local government and other service utilities. Consideration shall be given to factors such as whether the obstruction is inappropriately in the water main allocation and the effect of the item on water main construction and/or maintenance.

4.9.3 Clearance from structures and property boundaries

For water mains located close to structures such as foundations for brick walls and buildings, the main shall be located clear of the “zone of influence” of the structure foundations to ensure that the stability of the structure is maintained and that excessive loads are not imposed on the water main or its embedment zone.

The minimum offset from property boundaries shall be consulted with SLRA

4.9.4 Underground obstructions and services

4.9.4.1 General

Details of underground services shall be obtained from the relevant Owner.

None of the underground trenching work should be started unless with the written consent from Sierra Leone’s appropriate government body which has information on all underground assets names etc. or at least with the Water Authority’s consent letter.

4.9.4.2 Clearance requirements

For trenched installations, clearances from other service utility assets shall not be less than (*and preferably exceed*) the minimum vertical and horizontal clearances shown in below table 6

Table 6: MINIMUM CLEARANCES FROM OTHER UTILITY ASSETS

Utility (Existing or proposed service)	Minimum horizontal clearance (mm)		Minimum vertical clearance (mm)
	New main size		
	=< DN 200	> DN 200	
Water mains > DN 375	600	600	300
Water mains =< DN 375	300	600	150
Gas mains	300	600	150
Telecommunication conduits and cables	300	600	150
Electricity conduits and cables	500	1000	225
Stormwater drains	300	600	150
Sewer - gravity	1000	1000	500
Sewer – Pressure and vacuum	600	600	300
Kerbs	150	600	150

5. PRESSURE BOOSTING AND MANAGEMENT

5.1 General

Water supply systems are generally planned and designed to use gravity to convey water within reticulation systems designed to provide for the customers' water demands within the pressure ranges. However, where variations in topography limits the viability of a gravity system or where pressures fall outside the required pressure ranges, other means of ensuring appropriate pressures need to be employed.

If the minimum pressure (15 to 50 bars) is insufficient during delivery of seasonal demands, in-line pressure booster pumping stations may be used to increase the hydraulic gradient to the areas that have inadequate pressure.

5.2 In-line Pressure Booster Pumping Stations

5.2.1 Planning criteria

The use of boosters increases the risk of water supply interruptions (reduction in available pressure) due to loss of electrical power supply.

Unless approved by the relevant water utilities, water supply systems shall be planned and designed to exclude a boosted supply to customers such as:

- a) a hospital of any class;
- b) heavy industry customers; and
- c) other customers as nominated by the Water Authority.

In-line booster pumping stations, without associated high-level storage, may be used in situations where all of the following conditions apply:

- a) it is impractical to build a storage;
- b) the pump and motor can be replaced in 8 hours;
- c) no more than 150 property connections will be without water when the pump is offline;
- d) the pump motor is variable speed; and
- e) Duty/Standby pumps shall be provided unless otherwise approved by the relevant Water Authority

5.2.2 Concept design

5.2.2.1 General

When a booster concept design is undertaken in accordance with this Code, the basis and technical inputs to the design shall be fully documented.

5.2.2.2 Life cycle considerations

Boosters shall be planned and designed to optimise construction, operation and maintenance costs for the total life cycle of infrastructure and equipment. The life cycle evaluation shall also consider community and environmental impacts and implications.

Factors to be considered in the choice of booster type, equipment and arrangement of pumps shall focus on minimising the total life cycle costs of the booster including:

- a) initial capital cost of booster, including cost of land and easements;
- b) operating costs (including energy) and maintenance costs over the life of the booster; and
- c) life expectancy and replacement cost of pumps, valves, switchgear and ventilation equipment.
- d) Provision should be made for balancing reservoir and service tank

5.2.2.3 Functionality

Boosters and associated works shall be designed to:

- a) boost pressure to a maximum of 300 lots in the ultimate boosted zone;
- b) meet firefighting requirements (if required) in accordance with the NFF and the relevant Water Authority requirements;

- c) in consultation with SLSB and EPA-SL, meet regulatory noise and vibration requirements
- d) incorporate remote monitoring, control and telemetered alarms (if required);
- e) provide safe working conditions for operation and maintenance personnel; and
- f) in consultation with the Local councils, satisfy local zoning requirements.

5.2.2.4 Due diligence requirements

The Concept Design for a booster and associated works shall address all appropriate due diligence requirements.

A contingency plan shall be developed for booster failure based on a risk assessment and the normal operating and maintenance practices of the Engineer. The contingency plan shall include provision of:

- a) standard arrangements for emergency bypass of the booster pump;
- b) standard connection on the electrical cubicle for a mobile generator;
- c) stand-by pumping equipment and associated controls;
- d) spare pump(s); and
- e) easy all weather access for maintenance and emergency activities.

5.2.2.5 Reliability

Boosters and associated works shall be designed to:

- a) operate reliably and automatically; and
- b) incorporate redundancy for all critical items so that failure of any one item does not cause total station failure.

5.2.2.6 Maintainability

Boosters and associated works shall:

- a) be designed to minimise person-entry;
- b) be maintainable using the relevant Water Authority's standard maintenance practices;
- c) incorporate dismantling means to accommodate axial separation of pump(s) within the booster for maintenance without causing interruption of water supply;
- d) incorporate valves for flexibility of operation; and
- e) utilise the relevant Water Authority's preferred (and authorised) equipment and devices.

5.2.2.7 Materials design

Boosters may present a range of corrosive environments that require careful materials design.

Protection against internal and external corrosion and material degradation shall be appropriate to the operating environment. The Concept Design shall address any potential issue that may impact upon the detailed materials design in terms of:

- a) performance;
- b) design life; and
- c) total life cycle cost.

5.2.3 Commissioning plan

5.2.3.1 General

The Concept Design shall include a plan for approval by the relevant Water Authority.

The Commissioning Plan should ensure that the booster(s) is capable of being made fully operational to the satisfaction of the relevant Water Authority before transfer of ownership. Process diagrams for a typical pre-commissioning and commissioning process

The Plan should address:

- a) Pre-commissioning procedures.
- b) Commissioning procedures.
- c) Handover.
- d) Sign-off.
- e) Supply of documentation at handover and sign-off.
- f) All documentation required to operate, maintain and resource the facility, including but not limited to:
 - g) Equipment technical specifications.
 - h) Work As-Constructed (As-built) drawings.
 - i) Risk analysis
 - j) Operation and maintenance manuals.
 - k) Resourcing requirements for ongoing operation of the facility.

5.2.3.2 Pre-commissioning

Pre-commissioning is the preparation of plant or equipment so that it is in a safe and proper condition and ready for commissioning and operation. It includes all aspects of plant operation such as safety, electrical, mechanical and instrumentation. Pre-commissioning is required to verify all the requirements of the needs documentation, drawings, and functional design specifications. Pre-commissioning is carried out by the Constructor (contractor) before Commissioning of the works is witnessed by the relevant Water Authority.

A pre-commissioning schedule shall be prepared to enable the Constructor (Contractor) to carry out the procedures in a logical sequence.

Specific requirements for pre-commissioning shall include the following as a minimum:

- a) Initial charges of lubricant in addition to any special lubricant requirements for initial flushing or treatment of the system or for "running in".
- b) Physical checks and tests such as completeness of assembly, rotational tests (including checking that the rotation of electrical motors is in the correct direction), alignment checks, balancing and vibration checks, temperature, pressure and flow measurements, clearances, belt alignment and tension etc., depending on the type of equipment.
- c) Electrical and instrument installation tests, including motor insulation tests and calibrating instruments against certified instruments and correcting as necessary.
- d) Tests of the correct functioning of automatic and manual control and protection equipment, including simulating danger conditions, mal-operations or failures, to check that all instruments and controls function correctly.
- e) Adjustment of instrument set points and alarm settings and proving correct operation of alarms.
- f) Equipment and system operating tests and scheduled items in accordance with the Specification.

- g) Certify compliance of each item in accordance with the Specification and submit a signed copy prior to commissioning.

Pre-commissioning record sheets shall be developed for each item of equipment to ensure results of tests are satisfactorily recorded and that all necessary checks or tests have been performed.

The Designer shall develop the pre-commissioning checklist as part of the Specification.

5.2.3.3 Commissioning

Commissioning is the running of the plant and equipment to ensure flow through the pumping system, carrying out any necessary testing and adjustments until it is ready and suitable for normal starting and running under service conditions.

Representatives of the Water Authority will participate in the commissioning and may elect to record an independent set of test results for evaluation.

5.2.4 System planning and modelling

5.2.4.1 Modelling

Modelling to satisfy flow and pressure requirements shall be undertaken for current, future and ultimate conditions along with the seasonal/climatic changes to ensure customers receive a basic water supply, as defined by the relevant Water Authority (the Regulators), at times of power failure and other circumstances when the booster station does not operate.

In consultation with the NFF, modelling for fire flows in the booster zone shall assume the booster is operative and non-return valves connecting the zone to other parts of the network are provided to maximise flow to assist in incident situations.

5.2.4.2 Minimum pressure affecting the area

If an accurate validated maximum hour model of the proposed or current system is available, this should give a good determination of the minimum pressure.

5.2.4.3 Number of affected properties within the low pressure zone

For new systems use a model to predict the number of affected properties.

For existing systems, use an accurate maximum hour model of the current system to determine the current number of properties that may experience pressure below the minimum pressure standard nominated by the relevant Water Authority.

5.2.5 Booster design

5.2.5.1 General

Boosters shall be designed to:

- a) boost pressure only, not be the only means of supplying water to services;
- b) where required by the relevant Water Authority (the Regulator), provide firefighting capability; and
- c) be efficient, particularly for low flows, which may require the use of multiple variable speed pumps (all of the same size for efficient maintenance).

Flow and pressure requirements shall be nominated by the relevant Water Authority (the Relevant).

5.2.5.2 Connection to the network

Boosters shall be located within and connected to the network such that the boosted pressure is retained within a pressurised zone. Non-return valves shall be provided at zone boundary connection points to maximise flow from the wider network, and improve water quality supply within the zone, when the network pressure is such that the booster is inoperative.

5.2.5.3 Maximum flow and pressure requirements

Hydraulic modelling shall be undertaken to determine the pressure required at the booster discharge which will provide the minimum zone pressure required by the relevant Water Authority at the most disadvantageous location within the zone under the maximum minute demand conditions. The required discharge pressure, the minimum suction pressure and the flow, under maximum hour conditions, shall be used to determine the maximum duty Head and Flow (H, Q) that the booster is required to achieve. The required discharge pressure determined by the model shall be used as the primary basis of booster control.

5.2.5.4 Design for minimum pressure boost conditions

The booster will be required to operate at times when network pressures are below the required discharge pressure, but significantly higher than 'worst case', so that the required pressure boost is minimal. Historical pressure data should be used preferentially to hydraulic modelling to determine minimum pressure boost requirements.

5.2.5.5 Design for minimum flow conditions

Similarly the booster will be required to operate under minimal or zero flow conditions.

Consideration shall be given to the initial status of development within the zone in order to determine minimum flow requirements.

Design for minimum flow conditions may involve:

- a) Single pump operation at minimum speed, which is the preferred method where minimum flows can be efficiently achieved by single pump operation.
- b) Pressure accumulator tank(s) and pump on/off cycling, which is required where very low or zero night-time flows are expected to occur.
- c) Restricted bypass where a small automatic valve controlled bypass (between suction and discharge headers) may be used where minimum flow is below single pump low-end capability but sufficient to avoid significant heating of the supply.

5.2.5.6 Booster configuration design

The designer shall determine the most appropriate configuration of booster design in consideration of the following:

- a) Land availability and site suitability for the configuration.
- b) Site and equipment security.
- c) Compliance with environmental noise regulations.
- d) Visual impacts on public amenity.
- e) The Water Utilities'/service providers' standard operating and maintenance practices and procedures.
- f) Operability and maintainability of the various configurations.
- g) OH&S requirements.
- h) The life cycle cost of the suitable configurations.
- i) Seasonal variation
- j) power supply and or renewable energy

5.2.5.7 Booster set and pump selection

Booster set and pump selection shall be consistent with the minimum life cycle cost of the booster required to efficiently and reliably deliver the range of duties for diurnal flows, peak or maximum hour flows and fire flows as specified by the relevant Water Authority.

The Designer shall determine the style of booster set and pump consistent with the booster configuration design. In most cases the configuration will require vertical multistage pump/motor units for which proprietary skid mounted packages are readily available.

The primary basis of design shall be the maximum duty (H, Q) that the booster is required to achieve under worst conditions. The number of pumps (n) required to meet this duty shall be as few as practicable and not be more than three (3) unless permitted by the relevant Water Authority. The number of installed pumps provided for the booster shall be n+1. To compensate for performance degradation over time, the required duty shall be met with n pumps operating at or below 47.5 Hz.

The possibility of achieving the minimum flow conditions with one pump operating at or above minimum speed shall also be considered in determining the number of pumps (n) required to meet the maximum duty.

All pumps shall be fitted with temperature sensors for no-flow protection.

The hydraulic performance of the booster set shall be defined by the operating range determined by all required maximum and minimum flows and corresponding pressures. It is the Designer's responsibility to determine the required duty range of the booster set and individual pumps or pump combination and the requirements and design criteria for ancillary equipment with consideration of the following factors, some of which are interdependent:

- a) Head rise to cut-out for satisfactory control to be achieved.
- b) Maximum number of starts/hr (not to exceed 90% of manufacturer's equipment capability guarantee).
- c) Maximum speed (not to exceed 95% of manufacturer's equipment capability guarantee) i.e. maximum H and Q achieved at 47.5 Hz.
- d) Minimum pump flow (pumps cannot run at zero flow).
- e) Accumulator pressure tank size (if required).
- f) Minimum operating head for pump – the Designer shall determine the methodology for accommodating minimum head of pump where this is greater than the minimum system head

The Designer shall include a requirement in the Specification for suppliers to provide the full details of proposed pump(s), associated ancillaries, operating parameters and limitations to allow full evaluation of options. Details to be supplied shall include at least:

- a) rated duty of both individual pumps and booster performance at maximum head/ maximum flow conditions;
- b) speed range;

- c) minimum single pump minimum speed flow;
- d) pressure accumulator tank size (where required);
- e) range of maximum and minimum operating duties (H and Q);
- f) maximum number of starts/hr;
- g) a description of operating system methodology to achieve starting, stopping and controlled operation of pumps relative to equipment operational boundaries and limitations;
- h) confirmation of the ability to allow gravity flow, where applicable; and
- i) maximum noise levels generated.

5.2.5.8 Booster pipework and manifold design

Individual booster pump pipework and manifolds shall be sized so that the maximum velocities do not exceed 1.5 m/s for pump suction and suction manifold and 2.5 m/s for pump discharge and discharge manifold or maybe determine according ISO 3354:2008. Slightly higher velocities may be used in consideration of cavitation, noise, vibration and possible equipment longevity impacts. Where practicable, pump discharge pipework shall also be small enough to ensure that non-return valves remain fully open under minimum flow conditions.

Table 7: FLOW VELOCITIES

Pipework Element	Maximum velocity in m/s
Pump suction and suction manifold	1.5
Pump discharge and discharge manifold	2.5

Unless otherwise required by the relevant Water Authority, all booster pipework shall be manufactured from seam welded pipe. Adjacent pumps shall be mounted with a minimum 300 mm clearance between adjacent suction and delivery flanges.

Suction and delivery manifolds shall be fitted with three 1/2" BSP tappings each fitted with stainless steel ball valves for connection of:

- a) Pressure gauges.
- b) Portable pressure recording equipment (provision for).
- c) Pressure transducers

5.2.6 Pressure accumulator tank

The number of motor starts permissible for either the booster station or for individual pumps will be limited by electrical equipment capabilities and may be further restricted by electricity supply company requirements.

One or more pressure accumulator tank(s) may be required to limit the frequency of motor starts during periods of low demand and to reduce pressure fluctuations to the customer.

The Designer shall be responsible for the specification of pressure accumulator tank(s), including the preparation of an inspection and maintenance schedule

Pressure accumulator tanks shall be of a diaphragm type with water and compressed gas phases completely separated and connected to the discharge manifold, which shall be provided with a flanged connection for the tank isolating valve and positioned so that the pressure tank, when mounted, does not interfere with access for maintenance of the pumps or any other system component.

Unless otherwise specified by the relevant Water Authority, the accumulator tank(s) shall be:

- a) designed, manufactured and tested-where:
 - i) the stored energy (Pressure x Volume) $P.V \leq 200 \text{ MPa.L}$;
 - ii) the maximum operating pressure $\leq 1 \text{ MPa}$;
 - iii) the tank net volume $\leq 500 \text{ L}$.
- b) designed, manufactured and tested in accordance with relevant ISO standards in (a) above are exceeded;
- c) designed to meet the operating pressure requirements for the pump and other hydraulic components including abnormal pressure conditions;
- d) fully certified and registered to meet regulatory requirements;
- e) manufactured using products (materials and coatings) suitable for contact with drinking water;
- f) manufactured from corrosion resistant products and materials;
- g) designed with mountings to minimise the likelihood of fatigue failure of connections due to vibration and operating loads; and
- h) connected to the discharge manifold by a pipe or high pressure braided flexible hose.

Pressure accumulator tanks shall be pre-charged with nitrogen gas to optimise vessel wall and bladder life.

5.2.7 Control and telemetry system

5.2.7.1 General

Design and installation of all instrumentation, control and telemetry shall comply with the relevant Water Authority's requirements.

All control systems shall be compatible with existing systems, terminology and processes used by the relevant Water Authority. These shall include, but not be limited to:

- a) Pumping control.
- b) Alarms.
- c) Telemetry system.

The telemetry system shall be capable of connection to the relevant Water Authority's telemetering system.

5.2.7.2 System requirements

The system shall monitor pressure in the discharge manifold of the booster set using a pressure transducer. The actual delivery pressure shall be compared with the set pressure within the pump control panel and when the system pressure falls below the set point pressure the pump shall start and operate at a required speed to maintain set point pressure. Starting and stopping sequences and variation of speed to maintain set point pressure shall be designed and tuned to achieve stable operation without causing transient pressure surges, oscillation of pressures and hunting of controls.

Control margins above and below the set point for the purposes of cut-in and cut- out functions shall be minimal consistent with achieving smooth stable control and shall be consistent with pump and system hydraulic characteristics.

The variable speed drive (VSD) shall start the pump motor at a rapid ramp rate to a minimum speed consistent with zero flow actual operating head conditions for the pump. The pump shall operate at the minimum speed for an adjustable time (typically 0 s, adjustable to 30 s), after which it will be controlled to maintain desired system pressure.

When the pump duty is no longer required, the VSD shall slow down to the preset minimum speed in accordance with the stop speed ramp such that the pump operates at a minimum speed for a brief period of time (adjustable to 30 s) before shutdown consistent with avoiding system pressure surges.

The VSD shall be set to limit the maximum speed and rate of change to values consistent with the pumpset and network limitations. The Designer shall be fully responsible for the integrated control philosophy and specifying provision of all equipment required to achieve the required output from the booster set without reduction in service life of pumps.

The Designer shall include in the Specification a requirement to supply details of the control philosophy in the tender schedule consistent with and in association with the information to be provided. The control philosophy shall specifically address issues of recognition of condition and control action when there is:

- a) flow less than pump minimum continuous flow condition (including no flow condition); and
- b) a low differential head condition relative to pump hydraulic coverage.

Consideration shall be given to low suction pressure, pressure transients; high delivery pressure etc. to safeguard the pump against low NPSHA and to operate in a minimum safe mode should instruments or the control system fail.

6. STRUCTURAL CONCEPTS AND FORCES ON PIPEWORKS

6.1 General

The water main installation shall be designed to resist structural failure. The design of flexible pipelines shall be in accordance with relevant ISO standard. Details of the final design requirements shall be shown on the Design Drawings.

6.2 Structural Considerations

Pipelines shall be designed to withstand all the forces and load combinations to which they may be exposed including internal forces, external forces, temperature effects, settlement and combined stresses. The water main design shall include the selection of the pipeline material, the pipe class and the selection of the embedment material to suit the proposed site conditions.

6.3 Internal Forces

Pipelines shall be designed for the range of expected pressures, including transient conditions (surge and fatigue) and maximum static head conditions and operating temperatures.

Transfer and distribution water mains subject to negative pressures shall be designed to withstand a transient pressure of at least 60 kPa below atmospheric pressure.

6.4 External Forces

6.4.1 General

The external forces to be taken into account shall include:

- a) Trenchfill loadings (both vertical and horizontal forces due to earth loadings).
- b) Surcharge.
- c) Effects of groundwater.
- d) Dead weight of the pipe and the contained water
- e) Other forces arising during installation.
- f) Traffic loads.
- g) Temperature variation (expansion / contraction)

The consequences of external forces on local supports of water mains shall also be considered.

Pipes shall be limited to stiffness $\geq 4,000$ N/m/m.

A typical arrangement of a buried pipe in a trench showing the embedment and trenchfill zones is given in Figure 11 below

In reference to Figure 11, a geotextile filter fabric surround system may be required where coarse granular embedment is used in a native soil that contains fines. The geotextile filter fabric prevents groundwater washing fines from the native soil into the embedment with consequential loss of structural support of the main.

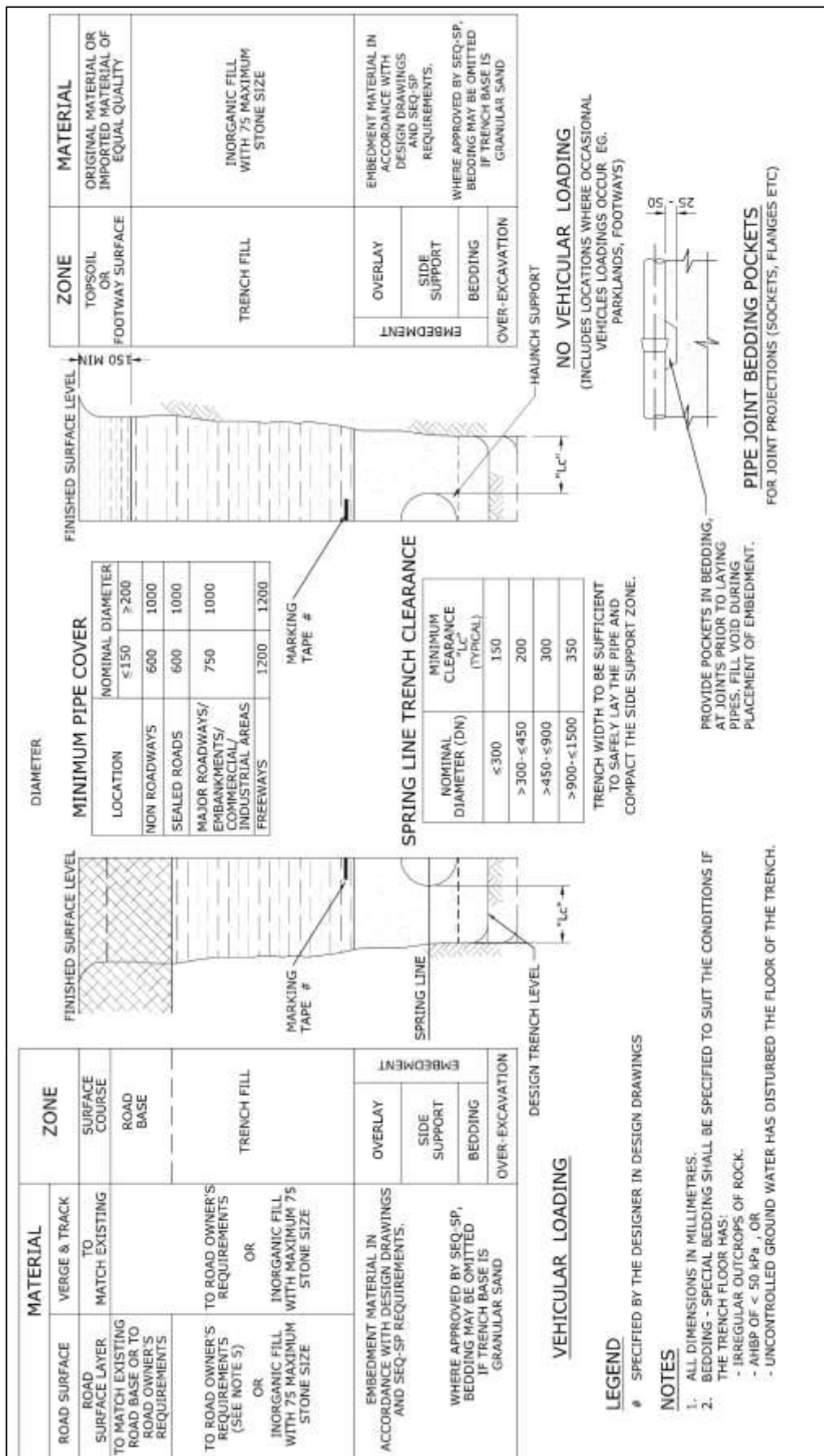

Figure 11: BURIED PIPE IN A TRENCH SHOWING THE EMBEDMENT AND TRENCHFILL ZONES

6.4.2 Pipe cover

Water mains shall have sufficient cover to:

- a) ensure any vehicular loading that is in excess of the loading capability of the water main, is transferred to the soil strata beyond the water main;
- b) suit the height dimensions (locally) of fittings such as valves and hydrants;
- c) meet the requirements of the road Owner (for water mains in road reserves); and
- d) meet any special requirements of the relevant Water Authority.

See table 8 for some typical figures for expected minimum cover over the buried pipe:

The relevant Water Authority's approval should be sought if the designer is planning to reduce the given figures.

Table 8: MINIMUM COVER OVER BURIED PIPE

LOCATION	MINIMUM COVER (mm)
Non-trafficable areas	
• General (Footways, easements etc.)	450
• Footways in major roads/ industrial areas	550
Trafficable areas	
• Driveways in industrial areas	600
• Carriageways of sealed local roads	600
• Carriageways of major roads	750

Cover shall be locally increased where necessary to accommodate stop valves, hydrants and other appurtenances.

6.4.3 Pipe embedment

Pipe embedment shall be specified in the Design Drawings and shall include the embedment material and, as appropriate, reinforcement details. Standard embedment types are shown in Figure 12, where the AHBP is 50 kPa or more.

Special bedding shall be specified to suit the conditions if the trench floor has:

- a) irregular outcrops of rock;
- b) AHBP of <50 kPa; or
- c) Uncontrolled ground water has disturbed the floor of the trench.

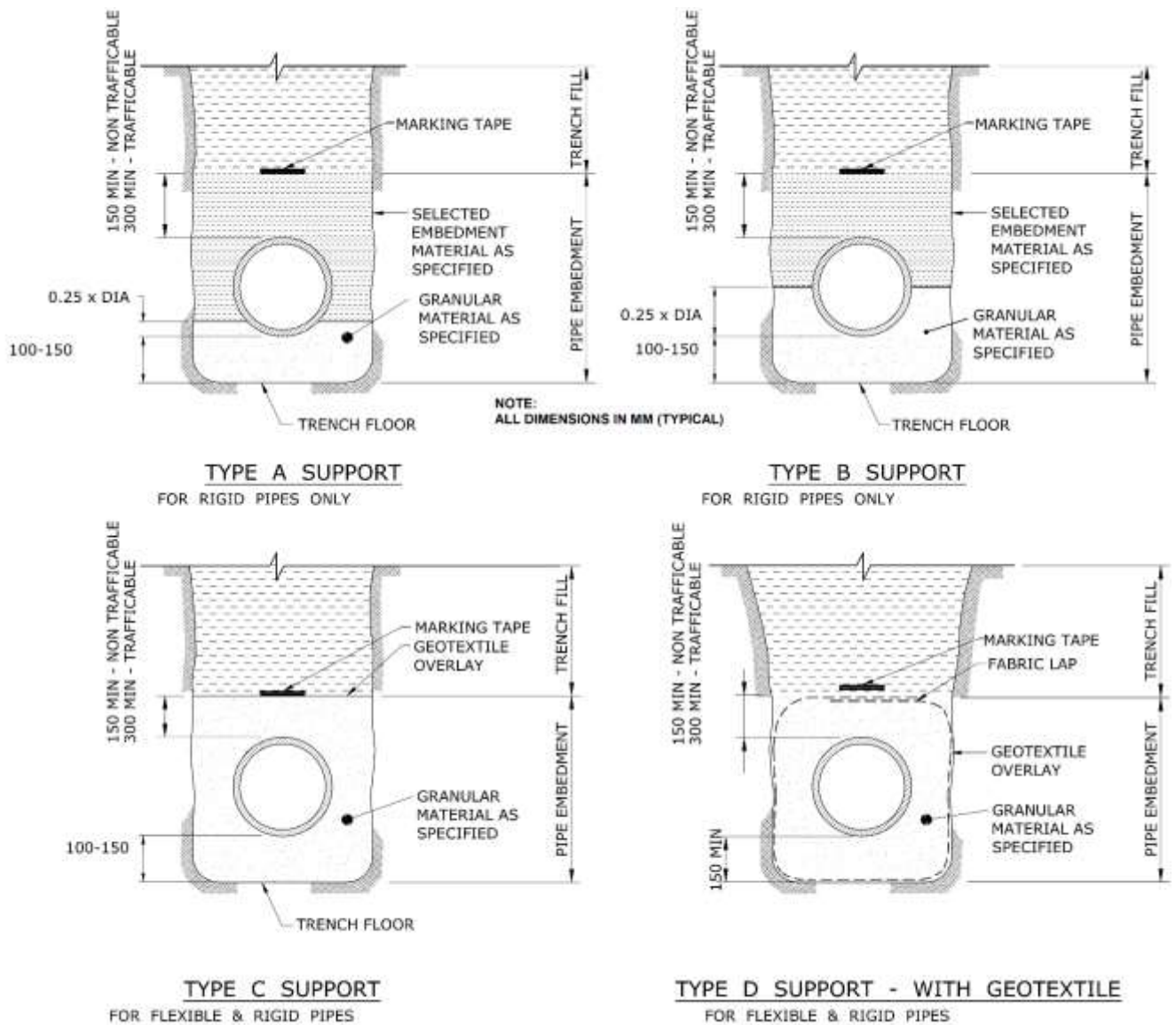

Figure 12: STANDARD PIPE EMBEDMENT TYPES

6.4.4 Buoyancy

Where necessary, pipelines shall be designed to resist the effects of buoyancy (flotation).

The Designer is responsible for the analysis and measures to address the effect of buoyancy where sections of the pipeline are to be laid in circumstances.

Buoyancy analysis shall be undertaken using the following criteria:

- a) an empty pipeline;
- b) water table is at ground surface level;
- c) the buoyancy force is resisted by the combined weight of the pipe and the rectangular prism of saturated trench fill material vertically above the pipe;
- d) the buoyancy force is equivalent to the weight of the volume of water displaced by the pipe; and
- e) a factor of safety against flotation is not less than 1.15.

6.5 Geotechnical Considerations

6.5.1 General

Unless otherwise specified, a geotechnical assessment shall be made of the proposed route of a distribution or transfer main of size \geq DN 375.

See below figures for some typical embedment details for grounds with low bearing capacities:

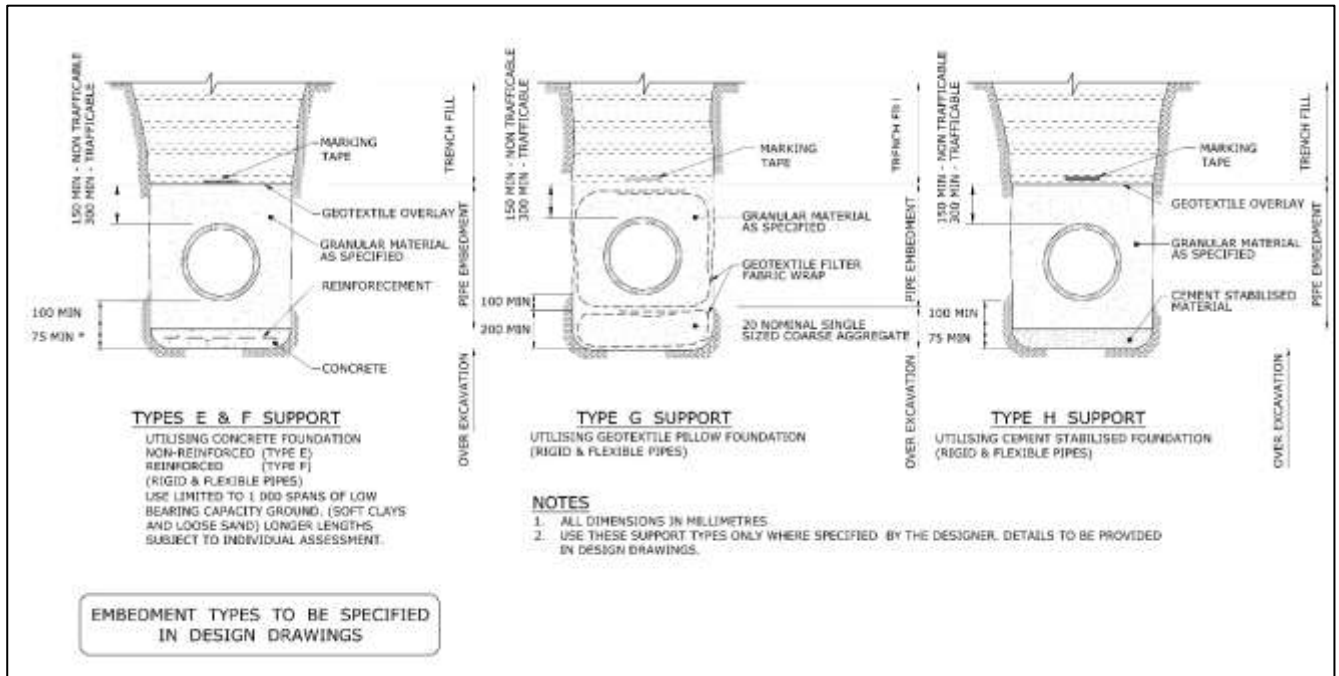

Figure 13: TYPICAL EMBEDMENT DETAILS FOR LOW BEARING CAPACITY GROUNDS

6.5.2 Construction of an embankment

Where the route of a main requires filling or construction of an embankment (e.g. to achieve required lines, grades and cross-sections), a geotechnical specialist shall investigate the site and design and supervise construction of the embankment, the trench and bedding for the pipeline. Relevant construction requirements shall be included in the Specification and/or Design Drawings.

6.6 Concrete Encasement

6.6.1 General

Where open trench construction methods are employed, concrete encasement shall be considered as an alternative embedment material where:

- there is a need to protect a main from external loading, typically where the main is laid in a major roadway or in a shallow trench;
- there is a need to reduce the need for future maintenance activity;
- gradients are 30% or greater;
- additional embedment material stiffness is required;
- the trench foundation is inadequate;
- buoyancy considerations may result in excessive uplift forces and
- the risk of erosion is high.

Proposals for concrete encasement and/or any alternative options shall be subject to discussion with and approval by the Water Authority.

Generally, the following types of pipe and fittings may be concrete encased:

- Welded steel pipe and fittings
- Ductile iron and PVC pipe.
- Welded PE pipe and fittings.

The following shall **not** be concrete encased:

- a) Cast iron, wrought iron and AC pipes.
- b) Lead joints.
- c) Flanged joints.
- d) Riveted pipe.
- e) Sections of any main containing a service connection, hydrant or valve (including air valves).

Some typical examples of concrete encased embedment are shown in Figure 14.

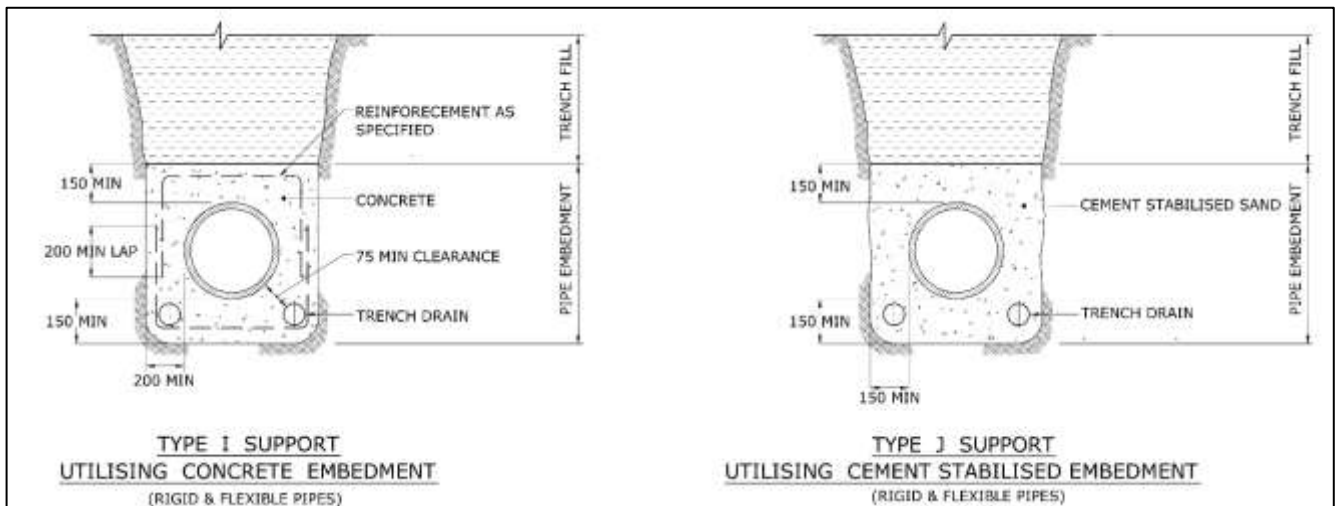

Figure 14: TYPICAL CONCRETE ENCASEMENT EMBEDMENT DETAILS

6.7 Pipeline Anchorage

6.7.1 General

Anchorage shall be provided at all changes in direction, slopes tees, valves, tapers and termination points, except for:

- a) in-line valves less than DN 250;
- b) those portions of restrained joint and welded pipelines deemed to be adequately anchored

In-line valves DN 200 and smaller need not be restrained as safe flow isolation practices are in place to limit the effect of system thrust forces during maintenance.

6.7.2 Thrust blocks

6.7.2.1 General

To anchor buried water mains with unrestrained flexible joints, thrust blocks shall be designed to resist the total unbalanced thrust and transmit all thrust loads to the adjacent native soil or rock. Calculation of the unbalanced thrust shall be based on the maximum system test pressure.

Thrust blocks for temporary works shall be designed to the requirements for permanent thrust blocks.

The size of the thrust blocks to be shown in the Design Drawings

The following formulas shall be used to calculate the resultant thrusts:

Bends
$$T = 1.54 \times 10^{-5} \times h \times d^2 \times \sin(\phi / 2)$$

The resultant thrust bisects the angle of the bend. A long lobster-back bend may need to be treated as two separate bends

Tees, Valves and Dead-Ends
$$T = 0.77 \times 10^{-5} \times h \times d^2$$

Tapers and Reducers

$$T = 0.77 \times 10^{-5} \times h \times (d_i^2 - d_s^2)$$

where:

T = resultant thrust in kN.

h = design pressure (head) in m head, which shall be the greater of the water main design pressure and the test pressure at the thrust block location.

φ = deflection angle of bend in degrees.

d = outside diameter of pipe in mm.

d_i = outside diameter of larger pipe in mm.

d_s = outside diameter of smaller pipe in mm.

6.7.2.2 Concrete thrust blocks

Minimum thrust area for typical concrete thrust blocks for pipes of sizes \leq DN 900 are provided in Table below: The Designer shall specify thrust block design details, to resist the unbalanced thrust load, in the project drawings.

Where a typical thrust block is not practicable (e.g. due to excessive size, site constraints etc.) the Designer shall specify alternative thrust restraint measures.

The table 9 shows requirements based on a system test pressure of 1200 kPa (120 m head)

Table 9: CONCRETE THRUST BLOCK

THRUST BLOCK LENGTH								THRUST BLOCK LENGTH									
PIPE DN.	FITTING	MAX. THRUST IN KN	THRUST BLOCK HEIGHT	STIFF CLAY 50 KPa.	VERY STIFF CLAY SANDY LOAM 100KPa.	SAND & GRAVEL HARDCLAY 150KPa.	SAND & GRAVEL CEMENTED WITH CLAY 200KPa.	ROCK 240KPa	PIPE DN.	FITTING	MAX. THRUST IN KN	THRUST BLOCK HEIGHT	STIFF CLAY 50 KPa.	VERY STIFF CLAY SANDY LOAM 100KPa.	SAND & GRAVEL HARDCLAY 150KPa.	SAND & GRAVEL CEMENTED WITH CLAY 200KPa.	ROCK 240KPa
100	90° BEND	19.8	400	1000	●	●	●	●	375	90° BEND	241.9	800	*	*	2220	1510	1260
	60° BEND	14.0		700	●	●	●	●		60° BEND	171.0		*	2140	1430	1070	890
	45° BEND	10.7		●	●	●	●	●		45° BEND	130.9		*	1640	1090	820	680
	22.5° BEND	5.5		●	●	●	●	●		22.5° BEND	66.7		1670	840	●	●	●
	11.25° BEND	2.7		●	●	●	●	●		11.25° BEND	33.5		840	●	●	●	●
	TEE OR CLOSED END	14.0		700	●	●	●	●		TEE OR CLOSED END	171.0		*	2140	1430	1070	890
150	90° BEND	41.7	450	1860	930	●	●	●	450	90° BEND	342.6	900	*	*	2540	1900	1590
	60° BEND	29.5		1320	660	●	●	●		60° BEND	242.3		*	2690	1800	1350	1120
	45° BEND	22.6		1000	●	●	●	●		45° BEND	185.4		*	2060	1375	1030	860
	22.5° BEND	11.5		●	●	●	●	●		22.5° BEND	94.5		2100	1050	700	●	●
	11.25° BEND	5.8		●	●	●	●	●		11.25° BEND	47.5		1060	●	●	●	●
	TEE OR CLOSED END	29.5		1300	660	●	●	●		TEE OR CLOSED END	242.3		*	2690	1800	1350	1120
200	90° BEND	71.7	550	*	1300	870	650	●	500	90° BEND	418	1000	*	*	2790	2090	1740
	60° BEND	50.7		1850	920	●	●	●		60° BEND	295.6		*	2970	1480	1230	
	45° BEND	38.8		1410	700	●	●	●		45° BEND	226.2		*	2260	1510	1130	940
	22.5° BEND	19.8		720	●	●	●	●		22.5° BEND	115.3		2310	1150	770	●	●
	11.25° BEND	9.9		●	●	●	●	●		11.25° BEND	58.0		1160	●	●	●	●
	TEE OR CLOSED END	50.7		1850	920	●	●	●		TEE OR CLOSED END	295.5		*	2970	1480	1230	
225	90° BEND	89.4	600	*	1500	1000	750	●	600	90° BEND	593	1100	*	*	2700	2250	
	60° BEND	63.2		2110	1060	700	●	●		60° BEND	419		*	2540	1910	1590	
	45° BEND	48.4		1620	810	●	●	●		45° BEND	320		*	2920	1950	1460	1220
	22.5° BEND	24.6		830	●	●	●	●		22.5° BEND	164		2980	1490	990	750	620
	11.25° BEND	12.4		●	●	●	●	●		11.25° BEND	82.2		1500	750	●	●	●
	TEE OR CLOSED END	63.2		210	1060	700	●	●		TEE OR CLOSED END	419		*	2540	1910	1590	
250	90° BEND	109.0	650	*	1700	1120	840	700	750	90° BEND	909	1300	*	*	2540	1910	1590
	60° BEND	77.1		2400	1200	800	●	●		60° BEND	643		*	2480	2060		
	45° BEND	59.0		1820	910	●	●	●		45° BEND	492		*	2530	1890	1580	
	22.5° BEND	30.1		930	●	●	●	●		22.5° BEND	251		*	1930	1290	970	810
	11.25° BEND	15.1		●	●	●	●	●		11.25° BEND	126.1		1940	970	650	●	●
	TEE OR CLOSED END	77.1		2400	1200	800	●	●		TEE OR CLOSED END	643		*	2480	2060		
300	90° BEND	158.6	700	*	2270	1510	1140	950	900 (0960 MSCL)	90° BEND	1.228	1500	*	*	2540	1910	1590
	60° BEND	112.2		2453	1230	820	●	●		60° BEND	868		*	2900	2420		
	45° BEND	85.9		1250	630	●	●	●		45° BEND	664		*	2960	2220	1850	
	22.5° BEND	43.8		630	●	●	●	●		22.5° BEND	339		*	2260	1510	1130	940
	11.25° BEND	22.0		●	●	●	●	●		11.25° BEND	170		2270	1140	760	●	●
	TEE OR CLOSED END	112.2		*	1600	1070	800	750		TEE OR CLOSED END	868		*	3300	2650		

THRUST BLOCK DIMENSIONS - 1200kPa
 ● INDICATES BLOCK LENGTH OF 600
 * = SPECIAL DESIGN

Some typical non-restrained pipework thrust block details is shown in Figure 15 for information

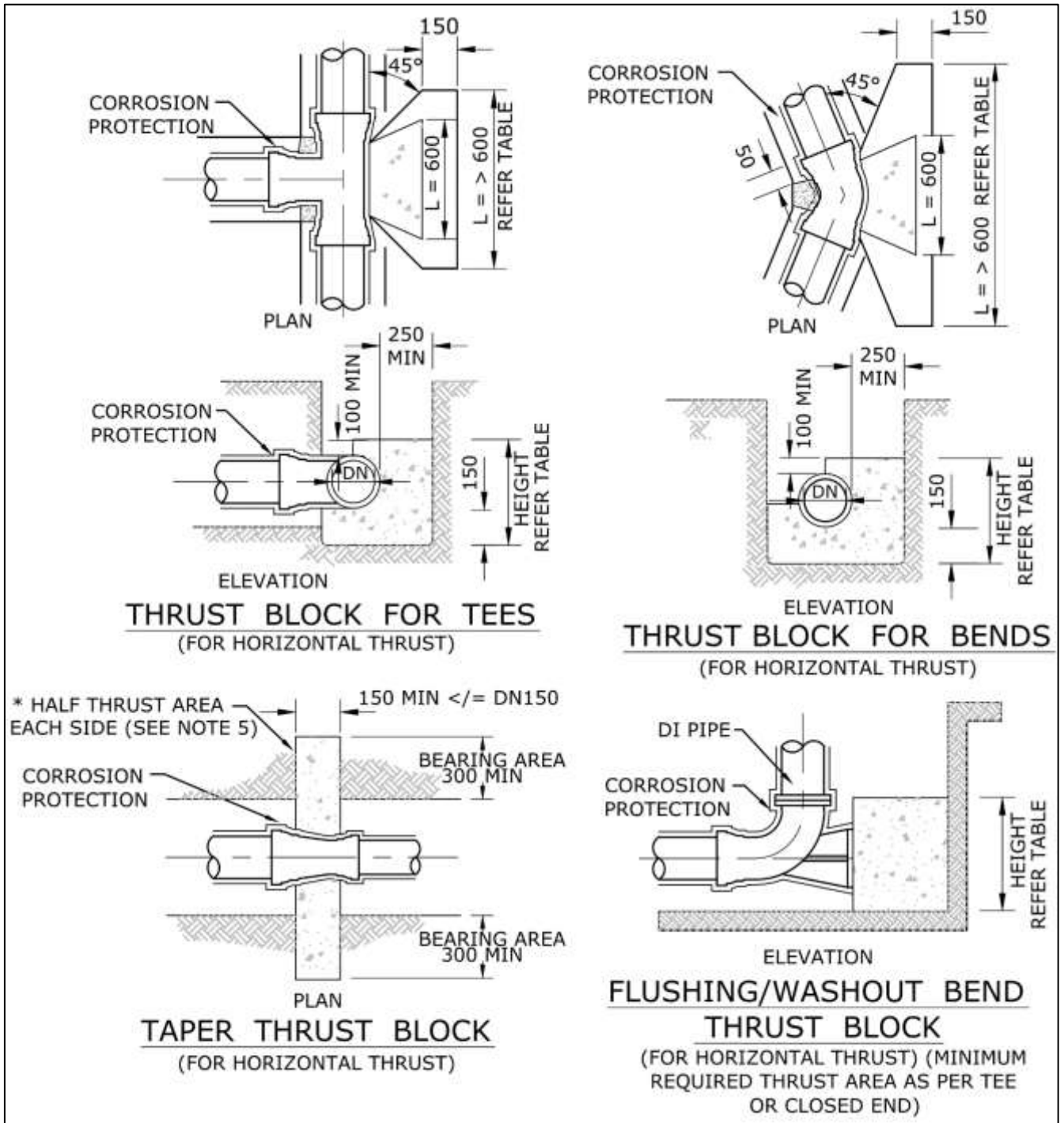

Figure 15: TYPICAL NON-RESTRAINED PIPEWORK THRUST BLOCK DETAILS

Typical concrete thrust blocks for valves including restraint mechanisms is shown in Figure 16 for information:

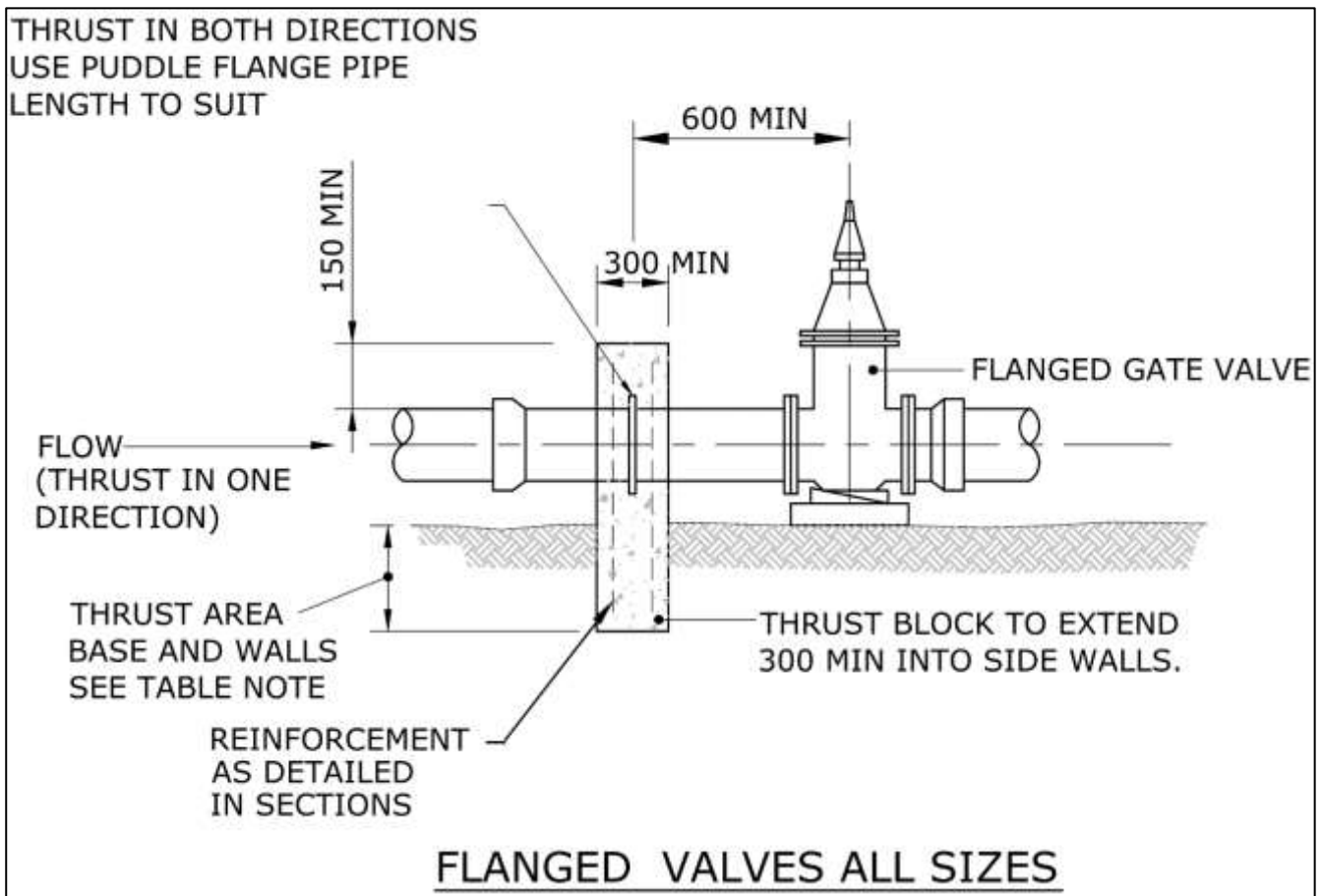

Figure 16: TYPICAL CONCRETE THRUST BLOCKS FOR VALVES INCLUDING RESTRAINT MECHANISM

6.7.3 Anchor blocks

Anchor blocks shall be designed to:

- resist the unbalanced thrust due to the maximum system test pressure; and
- prevent movement of pipe bends in a vertical direction and shall consist of sufficient mass or reinforced concrete to prevent pipe movement

Section 3 - Pipelines and Appurtenances

7. PIPELINE SYSTEMS AND PROTECTION

7.1 General

The following Sub-headings shall state requirements for pipeline component products and other construction items and materials and the corresponding product specifications.

Designers are responsible for nominating purchase specifications and/or Standards in project specifications to ensure that the contractor procure and install the correct products.

All products and materials used in contact with drinking water shall comply with UK WRAS approval (compliant with British Standards BS 6920:2014 *Suitability of non-metallic materials and products for use in contact with water intended for human consumption with regard to their effect on the quality of the water*)

7.1.1 Water supply mains – drinking water

Water supply mains conveying drinking water shall be constructed from pipes, fittings, valves and other appurtenances that comply with relevant British Standards (BS EN) and/or International Standards (ISO).

7.1.2 Property services – drinking water

Property services conveying drinking water shall be installed using pipes that comply with relevant British Standards (BS EN) and/or International Standards (ISO).

Table 10: PROPERTIES OF DRINKING WATER COMPONENTS IN A WATER DISTRIBUTION SYSTEM

Component		Drinking Water System
Reticulation Mains (or Mains)		
Pipe	PVC-U	Plain Blue
	PE100 Polyethylene	Plain blue OR black with blue stripes ¹ (Black with blue stripes preferred)
	Ductile Iron	Blue PE sleeving OR blue coating
	Galvanized Steel	No colour
Fitting e.g. bend, coupling		No colour
Valve (spindle cap)		Blue coating
Valve (body)		No colour
Hydrant (claw)		Red
Hydrant (body)		Red
Standpipe hydrants		No colour
Scours (outlets)		Blue coating
Marking tapes		Blue
Surface fittings and surrounds		Note 2
Signage (marker posts, plates etc.)		Note 2

Table 11: PROPERTIES OF DRINKING WATER COMPONENTS IN A WATER DISTRIBUTION SYSTEM

Component	Drinking Water System
Property Service Connections	
Galvanized steel pipes	No colour
PVC-U pipe	Plain Blue
PE100 PE pipe	Plain Blue ¹
Pre-tapped connector (plug)	Blue coating
Pre-tapped connector (body)	No colour
Tapping band or saddle	No colour
Fittings e.g. ball valve	No colour
Water Meters	No colour
Water Meter Boxes (lids)	Note 2

NOTES:

1. It is recommended that a combination of plain and striped pipes be used in water reticulation systems rather than all plain or all striped pipes.
2. To be coloured in accordance with relevant Water Authority's requirements and best practice.

7.1.3 Marking tapes

Marking tapes (detectable and non-detectable) for drinking water mains and property services shall comply with the below standards:

- Detectable warning tape - BS EN 12613:2001; and
- Non-detectable warning tape – to comply with the applicable parts of the following specifications

BS2782 (testing)

BS381c (colours)

BS3012 (plastics)

NJUG 4 Identification of small buried mains & services

NJUG 7 Recommended positioning of utilities

NJUG 9 Guidelines on positioning & colour coding of utilities

National Joint Utilities Group (NJUG) website

7.2 Ductile Iron Pipeline Systems

7.2.1 Sizes and configurations

The nominal diameter, pipe pressure classification (DN), joint type, length of pipes, types of fittings and the internal and external corrosion protection are detailed in the relevant Standards. The means of tapping the reticulation sized mains shall also be detailed in the Standards noting that:

- a) Pre-tapped connectors are required for property services on all new DN, 100 and 150 mains except where the use of pre-tapped connectors is determined to be impracticable, in which case mechanical tapping bands may be used.
- b) Mechanical tapping bands are required for property services on all new mains >DN 150 and for connections to existing DICL mains and above-ground DICL mains.

Direct tapping of all reticulation sized mains is not permitted.

7.2.2 Seal coating of lining

A seal coating, complying with ISO 2531:2009, shall be specified for all cement mortar lined pipes of all sizes.

7.2.3 Sleeving

PE sleeving shall be specified on all bituminous coated DI pipes applied in accordance with ISO 8180. Constructors shall be required to repair any damaged sleeving in accordance with the pipe and/or fitting manufacturer's instructions.

7.2.4 Screw-on flanges for DI pipes

Screw-on flanges for DI pipes shall be certified as conforming to ISO 2531: 1998

Any design incorporating a screw-on flange (Flange class DI pipe) shall ensure that the flange is fully supported in the installed condition. The Design Drawings shall include instructions for preventing loading of the flange during installation.

NOTE: Screw-on flanges depend on thread sealant to maintain leak tightness. Deflection arising from structural loading of the flange during installation or operation may crack the sealant.

7.2.5 Flanged joints

Flanges shall comply with ISO 9349:2017 (Flanges and their joints. Circular flanges for pipes, valves, fittings and accessories, DN designated. Cast iron flanges). The Design Drawings shall specify the type of flange gasket and the tightening sequence. Corrosion protection of bolted connections shall be specified in accordance with Clause 4.8.8.

7.3 PVC-U Pipeline Systems

The nominal diameter, pipe pressure classification (DN), length of pipes, types, materials and classes of fittings (including the internal and external corrosion protection) are detailed in the relevant Standards. The means of tapping the reticulation sized mains are as follows:

- a) Pre-tapped connectors are required for property services on all new DN 75, 100 and 150 mains except where the use of pre-tapped connectors is determined to be impracticable, in which case mechanical tapping bands may be used.
- b) Mechanical tapping bands are required for property services on all new mains >DN 150 and for connections to existing PVC mains and above-ground PVC mains.
- c) Direct tapping of all reticulation sized mains is not permitted.

The spigots of ductile iron fittings shall not be used with (inserted into) PVC-U pipe sockets.

Connecting the PVC-U pipes either by Solvent cement jointing (SCJ) or Rubber ring jointing (RRJ) is the discretion of the Water Authority depending on the operating pressure of the reticulation network.

Refer to ISO 1452-1:2009 Plastics piping systems for water supply and for buried and above-ground drainage and sewerage under pressure. Unplasticized poly (vinylchloride) (PVC U).for components and items used in PVC-U pipeline systems.

ISO 1452-1:2009 is a five-part publication which identifies the requirements for a piping system and its components made from PVC-U.

Part 1 General - specifies the overarching aspects of PVC-U pressure piping systems. It includes such items as definitions and characteristic of materials.

Part 2: Pipes - specifies the characteristics of solid wall pipes made from PVC-U (pipes with a socket and pipes without socket). Part 2 includes a range of pipe sizes and pressure classes, and gives requirements on colours.

Part 3: Fittings - specifies the characteristics of fittings made from PVC-U for solvent cementing and use with elastomeric ring seals. Fittings can be made by injection moulding or fabricated from pipe. It also covers PVC-U flange adapters (from PVC-U to other materials) and the corresponding flanges made from other materials. It sets

out the mechanical properties of fittings including any non-plastic components, together with geometrical and marking requirements.

Part 4: Valves - specifies the characteristics of valves or valve bodies made from PVC-U for solvent cementing, elastomeric ring seal joints and flanged joints. It sets out the mechanical properties of valves including any non PVC-U components, together with geometrical and marking requirements. Part 5: Fitness for purpose of the system - specifies the requirements for the assembled piping system (the pipes, fittings, valves and ancillaries in combination).

7.4 PE Pipeline Systems

The nominal diameter, pipe pressure classification, material class (PE 100), length and form of pipes (straight lengths or coils), types, materials and classes of fittings are detailed in the relevant Standards. The means of tapping the reticulation sized mains are as follows:

- a) Electrofusion welded tapping saddles shall be used at all times with new and existing installations of PE pipe. (Refer to WSA 01:2004 Version 3.1 - Polyethylene Pipeline Code) except where the use of electrofusion tapping saddles is determined to be impracticable, in which case mechanical tapping saddles may be used for:
 - i) tapping PE minor mains (<DN 63);
 - ii) rehabilitation installations using PE in sizes up to and including DN 180; and
 - iii) connections to existing PE mains and above-ground PE mains.
- b) Direct tapping of all reticulation sized mains is not permitted.
- c) Jointing of PE mains shall be specified in accordance with WSA 01:2004.
- d) All mechanical couplings shall be self-restraining.
- e) PE stub flanges and backing rings shall comply with PIPA Guideline POP007 and be sourced from the (Water Authority approved) supplier of polyethylene pipe or fittings.

NOTE: PIPA Industry Guideline POP007 provides guidelines for the geometric specification of metal backing flanges suitable for use with PE flange adaptors in the sizes DN 20 through to DN 1000 and flanges in accordance with ISO 7005-3:1988.

7.5 Steel Pipeline Systems

7.5.1 Sizes and configurations

The diameter, rated pressure, joint type, length of pipes, types of fittings and the internal and external corrosion protection are detailed in the relevant Standard.

Steel water mains shall not be used in reticulation systems without approval of the relevant Water utilities.

The relevant Water Authority may agree to alternative sizes and fitting types and dimensions.

7.5.2 Joints

Refer to the manufacturer for size availability and, dependent on the joint type and design, any allowable joint deflection.

Depending on the size of pipe, internal access for welding and reinstatement of lining may be required within limitations of person-entry.

7.5.3 Field welding

Refer the relevant ISO (Document No. 2 – Construction) for field welding requirements (ISO 3824:2005).

7.5.4 Flanged joints

The Design Drawings shall specify the class of flange, the type of flange gasket and the tightening sequence. Gasket types should generally be designated as either full face (FF) or inside bolt circle (IBC) or tongue and groove (TG) or spigot and recess (SR). Gaskets may be single flat sheet or laminated ply or moulded.

Corrosion protection of bolted connections shall be specified in accordance with the relevant ISO (Clause 7.6.8.)

Insulated flanged joints (See Figure 17) shall be provided where:

- a) specified on CP system Design Drawings; and
- b) steel pipes, fittings and other steel appurtenances are jointed to flanges and/or flange backing plates of dissimilar metals such as copper, copper alloys, galvanised steel and stainless steel.

Insulated flanged joints are not required where steel is flange jointed to:

- a) wrought iron flanges;
- b) grey cast iron flanges; and
- c) ductile cast iron flanges.

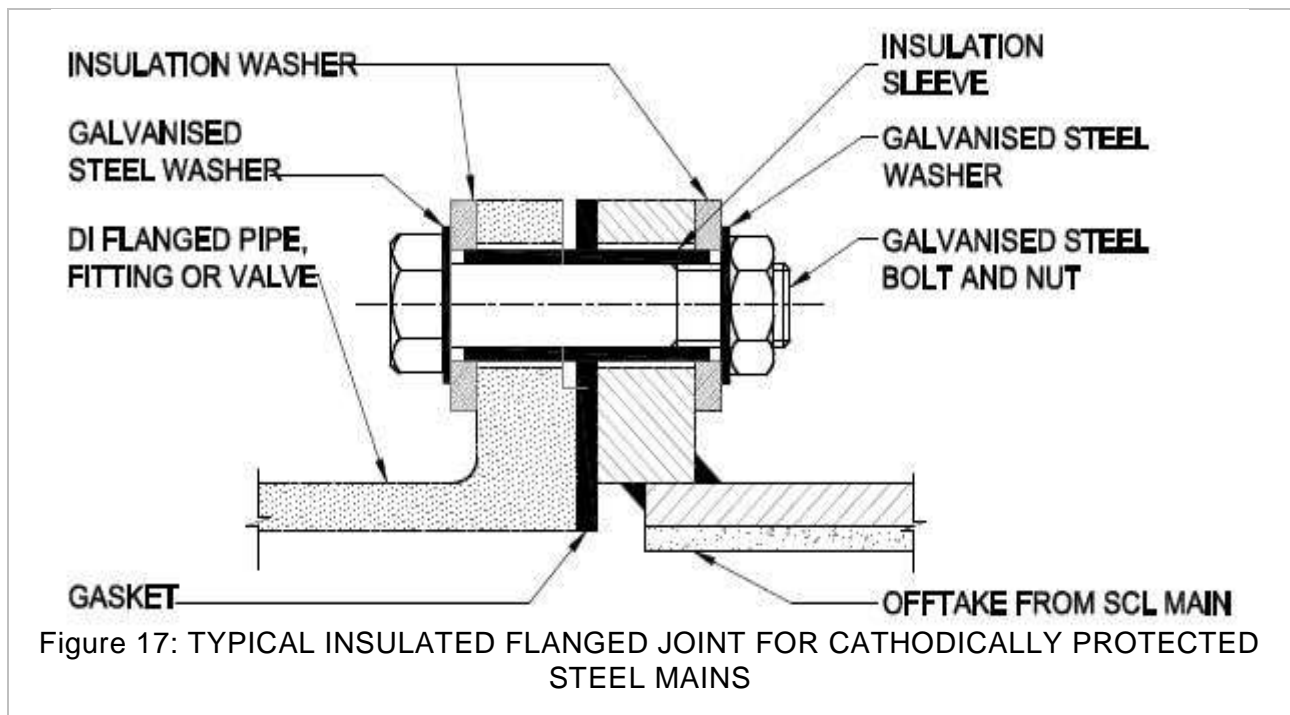

7.6 Protection against Degradation

7.6.1 Application

The protection of all pipeline system items (e.g. pipes, fittings, appurtenances, elastomeric seals) against degradation, principally corrosion, shall be addressed in the Design Drawings and Specification.

7.6.2 Protection against aggressive environments

Pipeline materials shall be selected to minimise the need for additional protection. If, however, other design factors dictate susceptible materials to be used, additional corrosion protection measures shall be specified by an experienced materials specialist.

Additional protection measures may include:

- a) eliminating contact between dissimilar metals to prevent galvanic corrosion;
- b) applying protective coatings for some metallic components and concrete structures, suitably designed for various corrosively levels of soil and groundwater;
- c) providing fully sealed conduits for plastics pipes and fittings in contaminated ground (see Clause 7.6.7);
- d) providing fully sealed conduits for all elastomeric seal jointed pipes and fittings in contaminated ground (see Clause 7.6.7);
- e) controlling trench fill and pipe embedment materials;
- f) mitigating of stray current or telluric effects on buried steel pipelines; and
- g) cathodic protecting buried steel pipelines.
- h) Consider all factors involving pipe ageing

7.6.3 Protection against damage to coatings

At least one thickness of PE sleeving shall be specified for insertion between coated fittings, valves and other appurtenances and thrust and anchor blocks. (Contractors) shall be required to repair any damaged sleeving in accordance with the pipe and/or fitting manufacturer's instructions.

NOTE: All fittings and valves are required to be coated with polymeric coatings.

7.6.4 Stainless Steel

7.6.4.1 Grade selection

Stainless steel items may be specified for pipeline components to achieve adequate corrosion resistance without the need for additional corrosion protection measures. Grade 316 or 316L is commonly adopted as the default requirement for buried applications.

With attention to material quality, joining techniques and fabrication practices, excellent performance can be achieved by a range of stainless steel types and grades for use within the typical range of drinking water conditions and chemistry defined by (SLSB) Guidelines for drinking water quality, 4th Edition 2017 and the soil and groundwater conditions expected in the majority of buried applications. Nevertheless, where any doubt exists, specialist material advice should be sought.

Suitable stainless steels are divided into four families:

- a) Austenitic
- b) Ferritic
- c) Duplex and
- d) Martensitic,

Which can contain:

- 16-30% Chromium;
- 1.5 – 18.5% Nickel;
- up to 7.0% Molybdenum;
- up to 1.0% Copper;
- up to 0.8% Titanium.

Electrochemical investigations to determine the critical pitting potential E_{pit} in chloride containing waters have led to the derivation of empirical indices to describe the resistance to pitting corrosion, in the form of a Pitting Resistance Equivalent Number (PREN).

For ferritic and martensitic grades (Fe-Cr-(Mo) alloys), the formula employed is:

$$PREN = \%Cr + 3.3 (\%Mo)$$

Where the concentrations are in weight (%)

For austenitic and duplex grades (Fe-Cr-Ni (Mo, N) alloys), the formula becomes:

$$PREN = \%Cr + 3.3 (\%Mo) + x (\%N)$$

where—

$x = 16$ for duplex stainless steels; and

$x = 30$ for austenitic stainless steels.

7.6.4.2 Welding

All welding shall be undertaken in accordance with international best practice (ISO).

The Standard includes a number of alternatives for weld quality and post-weld treatments. The Designer shall nominate specific requirements suitable to the application and operating environment in the welding specification. Guidelines for the specific requirements are discussed in the Standard.

7.6.4.3 Threaded components

To minimise the likelihood of galling (micro welding) of stainless steel threaded components, measures such as anti-seize treatments using PTFE and molybdenum disulphide coatings, rolled threads (as opposed to cut threads), a nut of significantly greater hardness than the bolt (e.g. a duplex stainless steel nut) and ensuring that fasteners are not over-torqued shall be adopted.

7.6.5 Cathodic protection

Cathodic protection (CP) is a technique that can be employed to minimise the risk of corrosion in buried metallic pipeline systems. It is usually used as a backup to coatings and not as a stand-alone corrosion protection system. CP is not a guarantee that corrosion will not take place. However, if a system is properly designed, it can prevent corrosion at areas of coating damaged during construction or by a third party and can effectively extend the life of buried metallic pipes for many years. CP installations can be costly in terms of initial installation and ongoing monitoring and maintenance within the life of the pipeline. Each situation should be considered to determine if it is cost effective.

CP systems shall be designed by an experienced specialist. The design shall include means for installing, inspecting and verifying performance of installation. Where CP is not mandatory and the Designer considers the use of CP is necessary, Water Authority's agreement shall be obtained before specifying CP.

Where metallic pipelines are laid in high risk areas such as old landfill sites, anaerobic swamps and tidal zones or other highly corrosive areas, the option of CP shall be investigated. Some Water Agencies require the use of CP systems on all steel pipelines.

When CP is considered as an option for buried pipelines, reference shall be made to BS EN 13636:2004 *Cathodic protection of buried metallic tanks and related piping*. This standard contains mandatory requirements and informative appendices detailing all aspects of CP system design, installation, commissioning, operation and maintenance.

Where CP is adopted, the design shall detail the special construction practices that will be required where pipelines cross major roads, tramways and railways. Where a CP system is installed on elastomeric seal jointed steel pipes, electrical bonding cables shall be fitted across all joints. Insulated flanged joints shall be used for electrical isolation of sections of pipelines where CP is to be employed and where isolation of magnetic flow meters is required to maintain accuracy.

O-rings are not suitable for use on insulated flanged joints unless a full face insulating insertion gasket is affixed to one side of the flange. Other means of isolation may need to be considered for water services and where pipework is connected to the electrical earthing system.

7.6.6 Stray current corrosion

Corrosion from stray electrical currents associated with inducted current from overhead power lines and transmission towers can have damaging corrosive effects on buried metallic pipelines. Investigations shall be carried out to ascertain the likely corrosion effects of stray current currents where metallic pipelines are:

- a) greater than 1 km long; and/or
- b) within 100 m of a CP impressed current anode ground bed; and/or
- c) for overhead power lines and transmission towers (Refer to Clause 4.4.9).

Cathodic protection can be utilised to reduce these effects but specialist advice should be sought.

7.6.7 Protection against contaminated ground

Ground contaminated by organic compounds, such as hydrocarbons and chlorinated hydrocarbons, may have an adverse effect on the:

- a) Quality of water, which may be contaminated by permeation of specific organic substances through the wall of plastics pipes and all pipe systems that have exposed elastomeric sealed joints.
- b) Properties of some plastics components, PE sleeving and polymeric coatings.
- c) Permeability and durability of elastomeric seals and gaskets.
- d) Corrosion resistance of some metallic components.
- e) Durability of cementitious materials.

Where a water main is to be laid in contaminated ground, suitable measures shall be taken to protect the main from ingress of harmful compounds. All water main components shall be protected.

Protection measures may include:

- a) fully sealed conduits for plastics pipes and fittings in contaminated ground; or
- b) fully sealed conduits for all pipes and fittings with exposed elastomeric sealed joints in contaminated ground; or
- c) additional corrosion protection for metallic components such as petrolatum tape wrapping; or
- d) coating of cementitious materials.

The design of water mains in locations where organic contamination is suspected or known (e.g. old land fill sites, old chemical industry sites and old oil refinery and storage sites) shall include investigation and adoption of appropriate protection measures.

The investigation shall be carried out by a suitably qualified independent consultant and shall:

- a) Characterise the organic contamination within the area of the proposed water main system;
- b) Assess the long term effects on pipeline materials and coatings, and the potential impact of the contamination on the water supply;
- c) Assess the OH&S risks during construction, operation and maintenance of the proposed water mains in relation to the identified contamination; and
- d) Make recommendations on the required materials (including elastomeric seals where employed), protection systems, construction methods and containment and mitigation measures.

Assessment of OH&S risks as mentioned in Item (c) will consists of:

- i) environmental hazards;
- ii) fire hazards;
- iii) security and safety hazards;
- iv) public safety hazards;
- v) operational, essential and emergency services and security response capabilities; and
- vi) contingency bypass / replacement / recovery capability.

The default protection measure for transfer and distribution mains shall be a fully welded externally coated or wrapped steel pipeline. Any proposed alternative shall be submitted to the Water Authority for approval.

The investigation report shall form the basis of the design for the reticulation system and be referenced on Design Drawings. It shall be provided to the relevant Water Authority as part of the design review process and shall be provided formally as part of the As-built drawings documentations.

Guidance notes for laying drinking water pipelines in contaminated ground are outlined in Foundation for Water Research Report No. FR 0448 (Laying Potable Water Pipelines in Contaminated Ground, Guidance Notes Nov 1994).

7.6.8 Bolted connections

Bolted connections using Grade 316 (see note below) stainless steel bolts, nuts and washers (and backing plates if required) of fusion-bonded plastics coated metallic flanged fittings and/or flanged PE pipes and fittings do not require additional corrosion protection.

Bolted connections using galvanised steel bolts, nuts and washers (and backing plates if required) of fusion -bonded plastics coated metallic flanged fittings and/or flanged PE pipes and fittings shall be provided with additional corrosion protection in the form of an encapsulating system of bolt head and nut sealing caps filled with corrosion prevention priming paste wrapped with petrolatum tape or with PE sleeving and taped.

Refer to figures 18, 19 and 20.

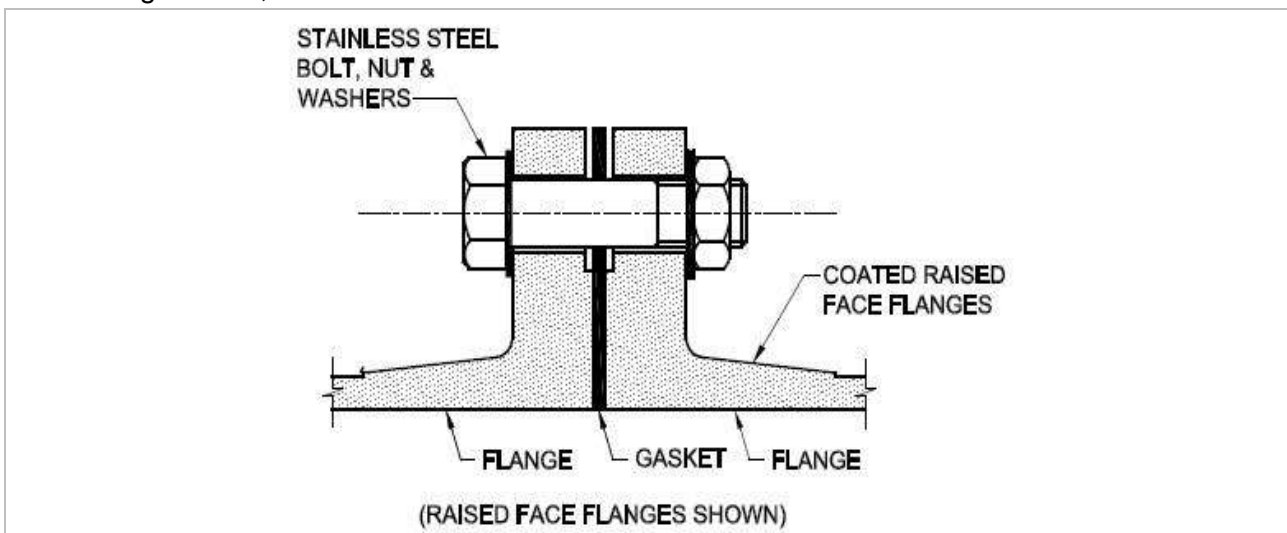

Figure 18: TYPICAL BOLTED CONNECTION DETAIL FOR FUSION BONDED COATED DUCTILE IRON FLANGES WITH STAINLESS STEEL FASTENERS

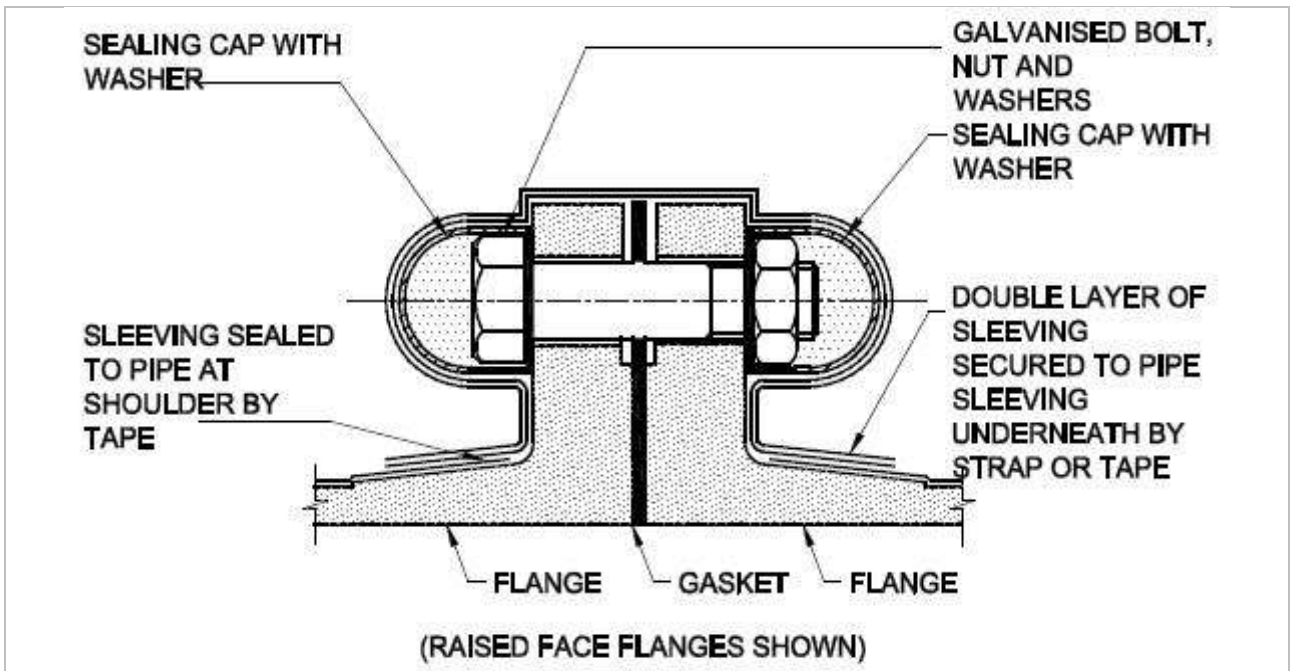

Figure 19: TYPICAL BOLTED CONNECTION DETAIL AND CORROSION PROTECTION PROCEDURE FOR BURIED DUCTILE IRON FLANGES WITH GALVANISED STEEL FASTENERS

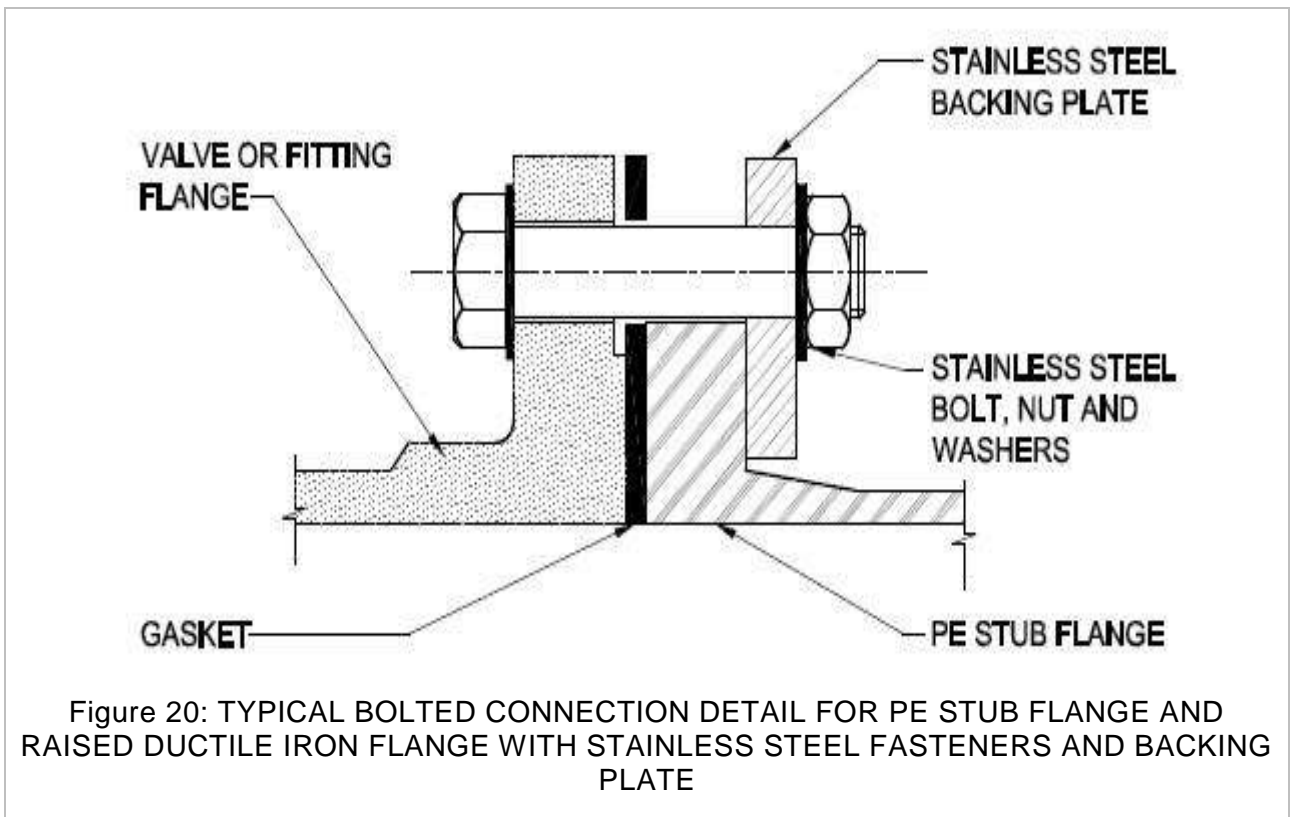

Figure 20: TYPICAL BOLTED CONNECTION DETAIL FOR PE STUB FLANGE AND RAISED DUCTILE IRON FLANGE WITH STAINLESS STEEL FASTENERS AND BACKING PLATE

8. VALVES, SCOURS AND ANCILLARY PIPELINE PRODUCTS

8.1 Valve – General

8.1.1 Valving design

The Designer shall identify the need for valves and their installation requirements. The Design Drawings shall detail their type, class, end connections, location and arrangement. This Interim Water Code for Sierra Leone document addresses the following types of valves:

- a) Stop (isolating) valves that are used to permanently or temporarily stop flow including use in bypasses and scours.
- b) Control valves that modify the flow rate (Flow Control Valves) and pressure in the system.
- c) Air valves that are used to expel air on filling or prevent a vacuum on emptying.
- d) Non-return valves that are used to allow flow only in one direction.

8.1.2 Valve siting principles

Valves shall be sited to provide the desired control (flow, pressure, isolation, diversion etc.).

Ready access to valves shall be allowed to enable their safe operation. Account shall be taken of traffic and other site peculiarities. Avoid locating valves within paved surfaces, where practicable.

Minimise inconvenience to the public by avoiding clustering of surface fittings in the footway at intersections.

Optimise the number and location of valves and hydrants to meet the Water Authority's operation and maintenance requirements.

8.1.3 Selection considerations

The Designer shall address the following issues when selecting valves:

- a) Life cycle cost.
- b) Range of flows, pressures and temperatures.
- c) Rated pressure and maximum operating temperature of the valve.
- d) Head loss characteristics.
- e) Sealing requirements - allowable leakage, if any.
- f) End connections, including flange drilling and gaskets.
- g) Duty cycle performance.
- h) Operational requirements.
- i) Cavitation / vibration.
- j) Noise level under operation.
- k) Availability.
- l) Valves opening clockwise directions

8.1.4 Local in-line booster pumping stations

Bypass pipework and valves shall be provided for the satisfactory isolation and performance of the local in-line booster pumping stations.

A bypass is provided to maintain supply to customers in cases of a booster being serviced or its failure for whatever reason e.g. power failure.

Bypass pipework shall be sized to carry the normal gravity flow without excessive frictional losses.

Larger diameter delivery pipework may be advantageous, particularly where a long delivery main is necessary.

Consider all factors for a compatibility of seamless operations between the system in use and the new system being introduced.

Each pump shall be provided with suction and delivery stop (isolating) valves to facilitate maintenance and removal and replacement of the pump

Pressure tanks shall be provided with stop (isolating) valves at their inlets to isolate them from the booster pumpset manifold.

Non-return valves shall be provided:

- a) in each pump delivery line; and
- b) on the bypass to prevent backflow.

Flange dimensions and drillings shall be specified to be in accordance with ISO 657-15:1980 DN16. Where pump isolation and non-return valve flanges do not match the pump flanges, adaptors (spool pieces) shall be provided to achieve flange compatibility with ISO 657-15:1980 8.1.5 Plastics identification covers

Where required by the relevant Water Authority, coloured plastics identification covers shall be provided for the valve spindle caps.

Consideration shall be given to above-ground valve installations to ensure a safe operating environment.

Where a permanent operating hand wheel is provided, its location in relation to the work platform shall reflect good ergonomic design principles.

Full size or reduced size chambers may be used depending on the relevant Water Authority's requirement.

8.2 Stop Valves

8.2.1 Installation design and selection criteria

8.2.1.1 General

Consideration shall be given to the expected range of operating pressures and flows when selecting the appropriate type of stop valve. This shall include the differential pressure expected when the valve is to be opened / closed, and the need for gearing to overcome the cracking torque.

Guidelines for gearbox selection and application are available in BS EN 1074.1 & 2:2000. Although these guidelines apply to gate valves, the information provided can be applied to other types of stop valves.

8.2.1.2 Gate valves

Valves shall have clockwise rotation of the input spindle for closure, unless otherwise specified by the Water Authority. End connections (socket/spigot/flange) and other issues such as anchorage shall be to the Water Authority's requirements.

The details of gear ratio and the number of turns of valves shall be shown on the Design Drawings.

Gearing shall be provided for:

- a) DN 16 valves of size >DN 400; and
- b) DN 21, 25 and 35 valves of size \geq DN 400.

For DN 16 valves of sizes DN 450 and DN 500, the Designer shall liaise with the relevant Water Authority to determine whether gearing is required.

Where specified by the relevant Water Authority, a valve chamber shall be provided for all geared gate valves.

A valve chamber shall be provided with a minimum of 600 mm horizontal clearance between the chamber walls and the pipework and have a drainage pipe of minimum 100 mm diameter. Prior to designing a valve chamber, the Designer shall consult the Water Authority concerning specific chamber requirements.

Buried ungeared gate valves shall be operated from above -ground and shall be designed to facilitate the use of a standard key and bar. An extension spindle shall be incorporated as necessary to ensure the top of the spindle is ≤ 350 mm below the FSL.

8.2.1.3 Butterfly valves

Butterfly valves are not normally used in reticulation mains as they limit swabbing operations. Double flanged butterfly valves are more often used in mains \geq DN 600 because of their lower life cycle cost and perhaps where space is a limiting factor, but only with the approval of the Water Authority.

All butterfly valves shall be geared unless otherwise authorised by the relevant Water Authority e.g. use of lever operated (ungeared) butterfly valves for air valve isolation is widely accepted.

A butterfly valve shall not be used in a situation where there is a requirement to throttle flow.

A valve chamber shall be provided if the gearbox of the butterfly valve is not sealed.

8.2.2 Stop valves for transfer/ transmission mains

Transfer main stop (isolating) valves shall be located at transfer main junctions and at maximum from 3 km to 5 km spacing. Distribution main stop valves shall be located at distribution main junctions and at maximum from 1 km to 2 km spacing. Closer spacing may be required at locations such as bridge, motorway or railway crossings.

Stop valves on distribution or transfer mains shall not be located under the road pavement unless authorised by both the Water Authority and the road Owner.

8.2.3 Stop valves for reticulation mains

In the reticulation network, including any pressure boosted zone, stop valves are used to limit the size of the 'shut-off' area when a main is taken out of service for operational purposes.

Stop valves \geq DN 100 shall be gate valves. In-line stop valves shall be the same diameter as the reticulation main.

Stop valves in mains $<$ DN 100 are generally gate valves although globe valves or ball valves may be used on mains \leq DN 75.

8.2.4 Stop valves for local in-line booster pumping stations

A stop (isolating) valve shall be provided on:

- a) each pump suction off-take;
- b) the downstream side of each non-return valve on the pump discharge pipework;
- c) suction and discharge manifolds to isolate the booster from the system; and
- d) each inlet to a pressure tank to isolate the tank from the booster pumpset manifold. The suction and discharge manifold isolating valves shall be fully sized to pipeline size. Isolating valves shall be:
 - a) resilient seated gate valves complying with ISO 16139:2006 or
 - b) if permitted by the relevant Water Authority, butterfly valves complying with ISO 16136:2006
 - c) If permitted, isolating butterfly valves shall be terminating style e.g. double-flanged or lugged to allow removal of the pump or non-return valve. Wafer style butterfly valves shall not be used.

ISO 16139:2006 Valves for water supply. Fitness for purpose requirements and appropriate verification tests.

Part 1: General requirements

Part 2: Isolating valves

Part 3: Check valves

Part 4: Air valves

Part 5: Control valves

Part 6: Hydrants

8.2.5 Bypass of stop valve

A bypass enables a stop valve to be operated under a balanced pressure condition or reduces the differential pressure across the main valve. A bypass also allows water mains to be filled through the bypass in a controlled way. In installations such as that for a PRV or PSV, involving two stop valves and a bypass, the bypass can be used to continue supply while the control valve is temporarily removed for service or replacement.

A bypass shall be provided around all valves on mains \geq DN 500 and around \geq DN 400 valves on mains where pipework of greater than PN 16 is required.

The default sizes of bypasses for stop valves shall be:

- a) DN 100 for water mains \leq DN 600;
- b) DN 150 for water mains $>$ DN 600 and \leq DN 1050; and
- c) DN 200 for water mains $>$ DN 1050 and \leq DN 1200.

Only gate valves shall be used on bypasses.

Where an integral bypass stop valve is proposed, or a bypass is being designed for a control valve installation, the required bypass flow capacity shall be assessed. This shall be based on the acceptable filling time for the pipeline between adjacent stop valves and/or the supply flow rate necessary for when the main valve is shut or out of service.

8.3.1 Pressure reducing valves (PRV)

Pressure reducing valves (PRV) are used to reduce the pressure upstream of the PRV to a desired lower downstream pressure. The PRV works automatically to maintain the desired downstream pressure.

The design of the PRV, including the type of valve and size, shall satisfy the requirements of the Concept Plan.

In determining the type and size of PRV, the following shall be determined and specified on the Design Drawings as appropriate:

- a) Cavitation resistance and control.
- b) Whether more than one valve in series is required to prevent cavitation.
- c) Whether an orifice plate upstream or downstream of the valve is required to keep cavitation under control. If so, also determine the design and size orifice.
- d) Whether a smaller PRV in parallel to the main PRV is required for satisfactory control of low flows.
- e) Whether a bypass is required for emergency situation and the degree of bypass capacity required.
- f) Means to control noise level to an acceptable level.
- g) Surge control on opening / closing of the valve. Specify a suitable opening / closing speed to keep surges within an acceptable limit.
- h) Availability of power, including emergency power supply, if the valve is electrically controlled.
- i) Telemetry and remote operation requirements.
- j) Whether a number of small PRVs in parallel are required to manage staged development.
- k) The fail-safe mode of the valve in the event of power failure, if electrically controlled i.e. open or closed fail-safe mode.
- l) Whether the PRV is to have a flow-control override to manage high demand conditions on the downstream side.

The Design Drawings shall nominate the most suitable valve for the application and any requirements applicable to the project.

PRVs are normally a hydraulically operated globe valve. However, electrically operated and suitably designed eccentric plug valves or butterfly valves could also be used as PRVs.

8.3.2 Pressure relief valves (PRelV)

Pressure relief valves (PRelV) are used to protect the water main by limiting the surge pressure in the water main within acceptable limits. PRelVs are set to open above a certain pressure

when the transient pressure in the water main exceeds the set pressure due to surge or other causes.

The design of a PReIV, including type and size, shall satisfy the requirements of the Concept Plan.

A valve shall be designed such that the set pressure is above the operating pressure of the water main to avoid frequent unwanted opening of the valve but shall be within the MAOP of the water main.

In determining the type and size of PReIV, the following shall be determined and specified on the Design Drawings as appropriate:

- a) Maximum pressure in the water main including surge.
- b) Operating pressure.
- c) Suitable set pressure.
- d) The discharge rate through the valve to keep the pressure within acceptable limits.
- e) Time to open in response to surge.
- f) Discharge pattern and drainage facilities.

The Design Drawings shall nominate the most suitable valve for the application and any requirements applicable to the project.

A PReIV is normally a hydraulically operated globe valve or angle pattern valve or a spring operated valve, which operates by releasing water to the atmosphere either in the form of a spray or jet.

8.3.3 Pressure sustaining valves (PSV)

Pressure sustaining valves (PSV) maintain a pre-determined minimum upstream or inlet pressure regardless of system demand.

The design of the PSV, including the type of valve and size, shall satisfy the requirements of the Concept Plan.

In determining the type and size of PSV, the following shall be determined and specified on the Design Drawings as appropriate:

- a) Cavitation resistance and control.
- b) Whether more than one valve in series is required to prevent cavitation.
- c) Whether an orifice plate upstream or downstream of the valve is required to prevent cavitation. If so, specify the material, shape and dimensions of the orifice plate.
- d) Whether a bypass is required for emergency situations.
- e) Means to control noise level to an acceptable level.
- f) Surge control on opening/closing of the valve. Specify a suitable opening / closing speed to keep surges within an acceptable limit.
- g) Availability of power if the valve is electrically controlled.
- h) Telemetry and remote operation requirements.
- i) The fail-safe mode of the valve in the event of a power failure, if electrically controlled i.e. open or closed fail-safe mode.

The Design Drawings shall nominate the most suitable valve for the application and any requirements applicable to the project.

PSVs are normally a hydraulically operated globe valve.

8.4 Air Valves (AV)

8.4.1 Installation design criteria

Water mains >DN 300 with a configuration that leads to air accumulation may require combination air valves to automatically remove accumulated air that may otherwise cause operational problems in the water system.

The configuration of the distribution network in terms of both the change in elevation and the slope of the water mains governs the number and location of air valves required.

Investigation into the need for air valves shall be made for all high points on transfer and distribution mains of size \geq DN 300, particularly those points more than 2 m higher than the lower end of the section of water main and particularly if the main has a steep downward slope on the downstream side.

Air valves shall be installed with an isolating valve to permit servicing or replacement without having to shut down the main.

8.4.2 Air valves type

Combination air valves i.e. (dual) air valves incorporating an air valve (large orifice) and an air release valve (small orifice) in a single unit, are generally the preferred type for distribution and transfer mains, and where required on reticulation mains.

Combination air valves shall be used at all locations requiring an air valve.

8.4.3 Air valves size

The nominal size of the large orifice of air valves shall be DN 80 for installation on mains \leq DN 600. This size has an exhaust capacity of 0.15 - 0.3 m³/s with a pressure differential of 14 kPa.

The nominal size of the large orifice of air valves shall be DN 100 for installation on mains \geq DN 700. This size has an exhaust capacity of 0.25 - 0.5 m³/s.

These sizes allow for filling the main using the bypass line around an isolating valve or the valve cracked slightly open.

8.4.4 Air valves location

The location of air valves shall avoid major roadways and areas subject to flooding, or alternatively valves shall be located above flood level.

When required on large mains, air valves shall be located:

- a) At summits (high points).
- b) At intervals of not more than 800 m on long horizontal, ascending and descending sections.
- c) At significant increase in downward slope
- d) At significant reduction in upward slope
- e) On the downstream side of PRVs.
- f) On the upstream side of a PRV when the PRV is located at the highest point.
- g) On the downhill side of major isolating valves.
- h) At blank ends.

Air valves on buried mains shall be located in a valve chamber with adequate venting for effective operation and drainage to prevent contamination due to backflow. The maximum depth of the chamber shall be 900 mm. Venting may be provided by means of a vented cover. Otherwise ventilation by means of an air ventilation pipe with a minimum diameter of 50 mm and terminating at a suitable location shall be provided. The drainage pipe shall be a minimum of 50 mm in diameter terminating at a suitable location to provide drainage of the chamber.

8.4.5 Use of hydrants as an alternative to air valves

Where required by the Water Authority, critical transfer and distribution mains may be provided with control-valved hydrants in addition to air valves, to assist in the movement of air during the dewatering/re-charging process as part of maintenance activities.

The factors that might be taken into account when considering the need for hydrants rather than providing air valves include:

- a) whether they can achieve some of the objectives that are usually met by providing air valves.
- b) a need for additional air removal capacity to meet shorter re-charging times than the drainage times

8.4.6 Water sampling via air valves

The Water Authority may specify provision of a small valved off-take from the body of an air valve for use in obtaining water samples.

8.5 Non-Return Valves

A non-return valve (or check valve or reflux valve) is a valve that normally allows fluid (liquid or gas) to flow through it in only one direction.

8.5.1 Installation design criteria

The design shall identify the need for non- return valves and any special installation techniques.

8.5.2 Typical installations of non-return valves

Non-return valves shall be provided:

Dual-plate non -return valves should generally be used providing extended shafts are not required. If an extended shaft is required, a tilting-disc non-return valve should be used providing slamming is not an issue.

A non-slam non-return valve should only be used if dictated by a water hammer analysis.

Non-return valves, with the exception of non -slam non-return valves, should be located a minimum of 5 to 8 pipe diameters away from a pump discharge in order to minimise flutter and consequent premature wear of components such as shaft and bearings.

Performance of non-slam valves should be based on deceleration values from the hydraulic transients' analysis in order to determine the appropriate spring closure rate. Non-slam valves shall be installed a minimum of 2 pipe diameters downstream of a turbulence generator e.g. pump, bend etc.

Non-return valves should not be buried. However, where permitted by the relevant Water Authority, dual-plate and non-slam non-return valves may be buried to avoid pit costs where circumstances are favourable e.g. bypass line around a booster or in a pipeline external to the booster.

All non-return valves shall be provided with adequate support and anchorage.

8.6 Scours and Pump-out Branches

8.6.1 Location and arrangements

Details and location of scours and pump-out branches shall be shown in the Design Drawings.

8.6.2 Design

Scours and pump-out branches are provided in the distribution network for maintenance purposes. They are designed to allow draining of water from the mains by gravity or use of a mobile pump

The design of scours and pump-out branches shall incorporate appropriate measures to prevent back siphonage into the water supply system.

The design shall ensure that there are adequate drainage facilities to receive the flow resulting from scouring operations. This shall be determined in consultation with the appropriate Regulator.

Scours shall:

- a) drain the water main by gravity and/or have provision for pump out within a specified time;
- b) have a diffuser fitted at the discharge point if there is a likelihood of environmental or asset damage; and
- c) not be subject to inundation from a flood due to a storm event of a frequency, as specified by the Water Authority, such as 1 in 2 or 1 in 5 year recurrence; and

d) be located so as to permit safe access and operation.

8.6.3 Scour size

Scour sizes to be 80DN when pipework is \leq DN 200, 100DN where pipework is $>$ DN 200 – \leq DN 300, 150DN where pipework is $>$ DN 300 – \leq DN 600 and 200DN is where pipework is $>$ DN 600

8.6.4 Scour location

Scours shall be located at:

- a) low points at the ends of water mains; and
- b) low points between in-line stop valves.

8.7 Swabbing Points

Swabbing points are designed to allow cleaning of mains.

For larger mains, such as transfer and distribution mains (\geq DN 375), the installation of dedicated swab launch and exit facilities shall be required.

Removable sections of main are also an option for swab launching and extraction. Experience would indicate that these sections are more usefully added after commissioning of the main at times and places to suit the relevant Water Authority.

For mains \leq DN 100, a foam swab can be launched through the standard hydrant head with the top removed and an adapter chute installed. Swabs can be exited at a selected hydrant again with the top removed and temporary pipework attached directly to the wastewater collection system.

Where swabbing points are required by the relevant Water Authority, the design shall ensure that there are acceptable and adequate drainage facilities readily available to receive the contents of the water main resulting from the dewatering and flushing operations. This shall be determined in consultation with the appropriate Regulator.

As a general rule, the relevant Water Authority does not require swabbing points to be provided.

8.8 Hydrants

8.8.1 Purposes

Hydrants are installed on reticulation mains for firefighting and/or operational purposes. Operational purposes include mains flushing, chlorination, and sampling and to allow the escape of air during charging and the release of water during dewatering of the water main, where air valves and scours are not installed.

8.8.2 Hydrant siting principles

In consultation with NFF, Some principles to be considered shall include:

- a) Site hydrants to facilitate flushing/swabbing of each section of water main. This may require a hydrant on each side of a stop valve in some locations.
- b) A single hydrant adjacent to a stop valve shall be provided on the upstream side, wherever practicable. *This facilitates flushing and air release when charging.*
- c) A minimum of one hydrant is required between two stop valves.
- d) Provide fire hydrants at regular spacing to facilitate easy location by fire brigade personnel.
- e) Provide fire hydrants opposite access ways to bush reserves and fire trails.
- f) Where a link main is laid in an access way or right of way between two streets, provide hydrants as necessary to satisfy spacing requirements
- g) Provide hydrants for operational purposes, e.g. chlorination, monitoring, sampling etc.

8.8.3 Hydrant types

There are three types of hydrants used in water reticulation systems:

- a) Spring hydrants attached to the main using a flanged hydrant riser (Refer to Figure 8.29) or attached to the flange of an isolating valve assembly (anti-clockwise opening) (Refer to Figure 8.30).
- b) Screw hydrants: consisting of either:
 - c) a screw down type valve seat assembly within the hydrant body, or
 - d) a coupling attached to an isolating valve assembly.

The hydrants are attached directly to the main using a flanged hydrant riser. Screw hydrants are installed on buried water mains in a hydrant box with cover and use a standpipe and/or a fire hose with threaded coupling to direct the flow of water.

- a) Pillar hydrants extend above-ground for ease of access and are used in some CBD areas and in specific locations such as in preservation precincts, rural areas and private installations. The type and style should be in accordance with Water Authority practice.

The preferred hydrant is the spring hydrant. In consultation with NFF, the relevant Water Authority approval is required for alternative hydrants.

8.8.4 Hydrant size

The spring hydrant is manufactured from a common body and flange casting with the option of either DN 80 or DN 100 flange drillings. Whilst DN 100 provides optimum flow when connected to a DN 100 hydrant riser, most Water Agencies currently specify DN 80 flanges and use a DN 80 hydrant riser. The screw hydrant is only available in DN 80.

8.9 Disinfection Facilities

8.9.1 General

The disinfection of water mains is usually achieved by injecting a solution containing free chlorine into the water main while charging the main with water through an adjacent valve. The process also requires the discharge of water from the other end of the water main.

Disinfection and water quality requirements shall be in accordance with Water Authority's procedures for disinfecting new mains. These procedures shall be obtained from the Water Authority prior to commencing work. Details of chlorination installation shall appear on design plans.

A new water main shall not be connected to the existing water mains network until it is disinfected. The disinfection practice requires temporary injection and discharge points using hydrants on bends at each end of the water main.

8.9.2 Reticulation mains

In reticulation mains, hydrants may be utilised for the disinfection process. If a hydrant is to be used for disinfection purposes, it shall be located adjacent to the stop valve to be used to charge the water main. A hydrant shall also be located at the end of the section of main to be disinfected to allow for the discharge of water.

8.9.3 Transfer and distribution mains

For transfer and distribution mains, where hydrants are not installed, appropriate disinfection fittings shall be installed. Acceptable options for enabling injection of disinfectant include installation of an air valve with a 20 mm ball valve tapping, or installation of a ball valve adjacent to a stop valve, together with an appropriate access arrangement.

Document 2 - Construction

Section 1 - General

9 GENERAL

This Document No. 2 of the Code provides default requirements for the construction of water mains and associated components and structures.

Prior to commencing construction in filled areas, mine subsidence areas, potentially unstable (slip) areas, areas containing acid sulphate soils and/or areas affected by salinity and any areas of concern to construction, consult the Designer to confirm special requirements.

Do not commence work until detailed Specifications and Design Drawings are available.

Construct the water supply transfer, distribution and reticulation Works to the lines, levels, grades and in the locations using the materials and methods as specified.

If insufficient detail or instruction is provided within the Design Drawings or Specification, seek instruction from the Designer prior to the commencement of the works.

Use only the types, materials, sizes, lengths, classes, jointing methods and corrosion protection systems for the pipes, fittings and maintenance structures as specified. Use only manufacturers' products and product range authorised by the relevant Water Authority.

9.1 Order of Construction, Testing and Commissioning

Undertake and complete all Works in accordance with the following process:

- a) Install all Works in accordance with the Design Drawings and the Specification and collect Work As-built information as work proceeds.
- b) Clean main(s) and property service(s) by both swabbing and flushing, air scouring or high velocity flushing.
- c) Conduct acceptance testing.
- d) Disinfect the main(s) and conduct acceptance testing.
- e) Connect the main(s).
- f) Charge and commission the new main(s).

9.2 Customer Focus

Ensure that the execution of the Works complies with the relevant Water Authority's "Requirements for customer service".

Fully brief (48 hours' notice to be given) all affected customers and property owners about the impact of the Works on buildings, noise levels, out of hours work, traffic restrictions, etc. before commencing work.

Keep documented evidence of contact details with all affected customers.

9.3 Protection of Property and Environment

Before work commences, ensure plans of all relevant services are available on site.

Prior to excavation, verify actual location of services that could affect the works using specialised search services.

Take special precautions where excavations are to be undertaken near any other structures or services including oil and gas pipelines, overhead and buried electricity and communication cables, drains, sewers and water mains. For these assets and any other services:

- a) Comply with the notification requirements and construction conditions as specified.
- b) Prove the location of all underground services (e.g. by pot hole).
- c) Take special care to ensure that other services are protected in accordance with the conditions specified by the service Owner.
- d) As appropriate for critical services, arrange for a representative from the service Owner to be present, unless the service Owner directs otherwise.
- e) Arrange for isolation and subsequent restoration of any service that needs to be removed from service while the Works are in progress.

- f) Adopt an appropriate method for exposing and protecting the service from damage if the service is to be exposed.
- g) Industry practices are generally to hand dig and locate underground services prior to machine digging.
- h) Immediately notify the owner or responsible authority of any damage or interference to any service, structure or property.
- i) If a service is damaged during construction, arrange or perform repair to the satisfaction of the Owner. Obtain from the Owner, a certificate stating that the repair has been carried out to their satisfaction.

9.4 Road opening permits

Coordinate with the relevant road authority (e.g. Road Transport Authority or Local Council) prior to commencement of any works within a road or road reserve.

Manage traffic in accordance with the requirements set out in the Road Transport Authority manual or any other relevant authority guidelines or practices associated to road works.

Section 2 – Product Management and Installation

10 PRODUCTS AND MATERIALS

10.1 Delivery Inspection of Products and Materials

Inspect all products and materials both before and at the time of delivery. Test report and certification of product and materials to be submitted immediately.

Quarantine any defective products such as those that are damaged, excessively distorted, outside their “use-by” date, unmarked or incorrectly marked and including, but not limited to:

- a). Faded/discoloured plastics and/or plastics-coated pipes, fittings and appurtenances.
- b). Kinked or crushed plastics pipes.
- c). PVC-U pipes and fittings scored deeper than 10% of the wall thickness to a maximum of 1 mm.
- d). PE pipes and fittings scored deeper than 10% of wall thickness.
- e). Electrofusion PE fittings not sealed in separate bags or cartons or with damaged sealed bags or cartons.
- f). DI and steel pipes and fittings with damage to linings in excess of 20% of the lining thickness.
- g). Plastics-coated pipes, fittings and appurtenances with damage to coating in excess of 20% of the coating thickness.

Indelibly mark or tag rejected products with wording such as “Do not use” or other identification and arrange for prompt removal from site.

10.2 Transportation, Handling and Storage of PRODUCTS AND MATERIALS

10.2.1 General

Transport, handle and store all products and materials in accordance with the manufacturers’ recommendations and in a manner that prevents damage or deterioration or excessive distortion.

10.2.2 Transportation

Support and secure all items during transit using straps or other suitable means to prevent excessive distortion or movement. Where supports, restraints and packing bear on item surfaces, provide suitable protection to prevent point loading, chafing, scoring, shock and other damage during transport. Do not allow wire straps, wire ropes or chains to come into direct contact with items.

Limit the heights of stacks of items to minimise distortion during transport. Where nesting and stacking of items is permitted, provide appropriate protection measures.

Stack items with end treatments such as flanges or preassembled fittings or couplings on pipes so that the ends are free from loading and/or damage.

Do not transport plastics items in covered trailers or containers unless appropriate means of preventing heat entrapment is provided.

10.2.3 Unloading and handling

Personnel involved in unloading and handling should wear appropriate personal protection equipment.

During unloading and handling pay particular attention to the protection of product and material coatings and linings and those surfaces that will be in contact with drinking water.

Damage to pipes and fittings during unloading and handling will be prevented by:

- a). ensuring the stability of the pipe stack, proposed unloading equipment and transportation vehicle;
- b). unloading on even ground;
- c). proper use of unloading equipment;
- d). correct site storage.

Promptly identify and perform in-situ repair of thermal-bonded polymeric coating on fittings and valves using approved materials in accordance with manufacturer’s recommendations.

Undertake field repairs of coated pipe in accordance with the manufacturer's recommendations.

10.2.4 On-site storage

Except for checking against the purchase order, keep pipes, fittings, valves, seals and other components delivered within protective crating or packaging, until immediately prior to use. Stack pipes in a manner that minimises pipe ovalisation.

Where necessary, pipes shall be supported clear of the ground on sandbags, soil mounds, timber bolsters or similar, at sufficient support spacing to prevent excessive longitudinal bending of pipe lengths.

While in storage all coated pipes, valves and fittings shall be supported on timber or rubber contacts not in contact with sharp or hard surfaces that might damage the coating and/or lining.

Stacking of pipes during storage shall be in accordance with the manufacturer's recommendations.

Do not store plastics pipe and fittings and plastics coated pipe and fittings near any heat emitting equipment.

Do not store PVC- U and non-black (excluding stripes) PE pipes and fittings uncovered in direct sunlight for more than twelve (12) months. If storage periods are likely to exceed twelve (12) months, cover and store pipe in a manner that allows ventilation and prevents heat entrapment. Do not store pipes under dark coloured (e.g. black) plastics sheeting or in any situation where the temperature may exceed 60 °C.

Use PVC and non-black PE pipe and fittings within two (2) years of manufacture.

Limit outside storage of black PE pipe with blue or purple stripes to a maximum of two (2) years from the date of pipe manufacture as marked on the pipe.

Store rubber sealing rings, lip seals and gaskets away from sunlight and in an unstrained condition.

Maintain the inside of all items clean and dry during storage. Use caps, plugs or blank flanges of a suitable design to seal open ends of items as necessary to prevent contamination during storage.

10.3 Rejected Products and Materials

Reject any damaged or defective products or materials.

Reject any unauthorised or unspecified products or materials unless written approval has been given for their use.

Do not use any rejected products or materials in the Works.

Place rejected products and materials in a quarantined area and arrange removal from the site at the earliest opportunity.

10.4 Concrete Works

Use premixed, normal class concrete to relevant standard specified by relevant Water Authority

Ensure concrete is delivered to site for use within 90 minutes of commencement of mixing at the batching plant.

Transport, handle, place and compact concrete so as to:

- a). limit segregation or loss of materials;
- b). limit premature stiffening;
- c). produce a monolithic mass;

- d). completely fill formwork, expel entrapped air, and closely surround all reinforcement, tendons, ducts, anchorages and embedment; and
- e). provide the necessary surface finishes.

10.5 Supply of Water to the Works

Use non-drinking water for construction works wherever practicable.

Due to the potential of contamination to the water supply system by backflow, fit a certified testable backflow prevention device or air gap so as to be visible on the tanker (vehicle) at all times when drawing water from hydrants/fireplugs.

For drawing water from fireplugs and hydrants other than by a water tanker, fit a certified non-testable dual check valve.

The relevant Water Authority shall be consulted to confirm the availability of water supply during the construction period. Introduction of water supply restrictions over the designated Works area may prohibit the supply of water to the site. Alternative sources of supply may need to be sought in the case of restrictions.

10.6 Supply of Water to existing properties

Maintain supply of water to existing properties affected by the Works to Water Agency requirements, which may require provision of temporary water supply piping.

10.7 Under Pressure Cut-in Connection to Pressure pipes \geq DN 80

10.7.1 Flanged off-takes

Supply flanged off-takes to rigid and flexible pipe (other than PE) to any BS / ISO equivalent. The material of make may be fusion bonded epoxy ductile iron or Grade 316 Stainless Steel.

10.7.2 Valves

Supply double-flanged gate valves to ISO 16139:2006

Supply an extension spindle to ISO 16139:2006

Cast iron (including grey and ductile iron) components shall not be welded.

Where the materials used are not corrosion resistant to soil and ground water (e.g. plain carbon or low alloy steels) the extension spindle shall be coated using bitumen paint or synthetic resin based protection systems or thermal bonded polymeric coatings.

Bitumen paint or Synthetic resin base coatings or Thermal-bonded polymeric coatings shall comply with BS 5493:1977.

Ensure the direction of spindle operation is in accordance with the relevant Water Authority requirements.

The direction of closing shall be Anticlockwise (ACC) and closing Clockwise (CC). Metal seated valve is preferred than resilient seated.

10.7.3 Flange holes

Ensure the hole diameter of the bolt holes in flanges requiring insulation sleeves is equal to the bolt shank diameter plus 5 mm.

10.7.4 Gaskets

Supply gaskets to ISO 7483:1991

Ensure the hole diameter of the bolt holes in gaskets requiring insulation sleeves is equal to the bolt shank diameter plus 5 mm.

10.7.5 Bolting system

10.7.5.1 General

Ensure the bolting system can provide mechanical isolation of dissimilar metals by use of insulation sleeves (with flange) to prevent contact between bolts / washers and flanges of dissimilar metals.

Supply sufficient sets of bolt assemblies for the number of holes in the flange being bolted.

NOTE: A bolt assembly includes 1 x bolt, 2 x washers, 1 x nut and 2 x insulation sleeves.

Check that all bolt shanks have a smooth machined finish and are free from protrusions before fitting the insulation sleeve.

Only use an electrically non-conductive lubricant or anti-seize compound.

10.7.5.2 Carbon or alloy steel bolt assemblies

These assemblies are used for SCL off-takes to valves and other flanged connections. Steel bolt assemblies may be used in above-ground applications (galvanised) or buried (galvanised or black).

Only use bolts, nuts and washers that comply with nominated Standards in the Specification and/or Design Drawings.

For buried applications protect the bolting system from corrosion by wrapping with an approved petrolatum based protection system.

For SCL pipes, provide insulation sleeves, except in cases where cathodic protection has or is to be applied, where special insulated joints shall be provided.

10.7.5.3 Stainless steel bolt assemblies

Stainless steel bolted connections may be used above or below-ground and do not require corrosion protection wrapping.

Only use Grade 316 stainless steel bolt assemblies that comply with nominated Standards in the Specification and/or Design Drawings.

Install insulation sleeves when using stainless steel bolts with any non-coated steel, cast iron or ductile iron flanges.

10.7.6 Insulation sleeves

Only use insulation sleeves made from acetal copolymer (POM) M-90 thermoplastic or similar.

Ensure the hole diameter of insulation sleeves is equal to the bolt shank diameter plus 5 mm and that the outside diameter of insulation sleeve flanges is equal to or greater than outside diameter of washers.

11 EXCAVATION

11.1 Precautions

Assess site for prior excavations and consider their impact on the new excavation.

Conduct a site hazard, EIA and safety assessment prior to commencement of any excavation to identify all potential hazards.

11.2 Limits of Clearing and Excavation

Keep the extent of clearing and excavation to the minimum practicable to allow efficient construction of the Works as Specified.

Unless specified otherwise, keep the sides of excavations vertical to at least 150 mm above the main.

11.3 Protection of Trees

11.3.1 General precautions

Obtain approval from the Owner and or relevant authority of the trees prior to excavation.

Avoid storing products and materials, including soil, rocks or gravel against trees or under tree canopies or above root zones.

Fence off trees to keep machinery away. Tie back stems and branches to keep them out of the path of machinery. Boring or hand excavation may be acceptable alternatives.

Carefully clean machinery between jobs to minimise the risk of soil-borne contamination between work sites. This is mandatory in areas where cinnamon fungus occurs.

11.3.2 Protection of roots

Take every precaution to ensure that no undue damage is caused to a tree root system as a result of excavation for the Works. Excavation for water main construction by hand or by trenchless techniques may be required to protect the root zone.

Cleanly cut all roots ≤ 60 mm diameter encountered during excavation.

Do not cut tree roots larger than 60 mm diameter without authorisation of the engineer.

Immediately trim back damaged roots or branches, including damage to bark, with a sharp saw to achieve a clean cut.

Apply an approved fungicide or mastic tar to reduce the likelihood of infection

11.4 Blasting

Do not use blasting unless authorised by the relevant Water Authority in collaboration with EPA-SL.

Obtain prior authorisation from the engineer, relevant Regulator and affected Owners of assets within the vicinity before undertaking blasting.

Submit a blasting plan that includes management of the blasting and means to be used

11.5 Support of Excavations

Support all excavations in accordance with:

- a) the Specification and/or Design Drawings;
 - b) any applicable Code of Practice for Safety Precautions in Excavation/Trenching Operations;
- and

Support all trenches of depth 0.6 m or greater or in unstable ground strata.

Ensure that adjacent structures and services are not subject to disturbance by the trench support system.

When removing, raising or withdrawing supports, ensure that no damage, disturbance or displacement occurs to the pipes, fittings, geotextile filter fabric, and pipe embedment and trench fill already installed. Ensure that compaction of pipe embedment and trench fill material occurs below such trench support and against native ground.

If the trench support system is to be left in place as permanent support, cut off the support system at a depth below-ground surface that will satisfy the structural and development requirements of the site.

11.6 Drainage and Dewatering

Keep all excavations free of water. Provide, maintain and operate intercepting works to prevent surface water from entering the excavations. Provide all equipment necessary for dewatering the excavations and keeping the Works free from water.

Only lower the water table by well points or other external dewatering methods if no damage is likely to be caused to adjacent structures and services or the environment.

Ensure that all downstream Works that are under construction, completed or in use are protected at all times against the effects of any drainage that is discharged or likely to be discharged from the Works.

Do not discharge dewatering to sewers, storm water drains or watercourses without appropriate authorisation.

If groundwater is encountered in the vicinity of a potentially unstable area, liaise with the Designer regarding possible additional design requirements.

11.7 Under Pressure Cut-in Connection to pressure pipes \geq DN 80

11.7.1 Excavation requirements

Expose the host pipe for a sufficient length to ensure the required distance from pipe joints and fittings will be achieved. Expose adjacent services and other obstructions to ensure sufficient clearances will be available

Excavate to a minimum of 100 mm below and behind the pipe to allow for installation of the off- take clamp. Provide additional excavation, as required, for placement of thrust blocks.

Excavate a safe working area, on the side to which the connection is to be made, to suite the space requirements for installation of the under pressure cut-in connection

Support the host pipe during excavation and drilling.

Other services may remain in the excavated region provided that they are not on the same elevation as the host pipe and sufficient clearances will be achieved.

11.7.2 Extent of excavation

Keep the extent of excavation to the minimum possible to allow efficient connection to the pipe. Provide sufficient space to safely and correctly cut-in the host pipe, to ensure that no other services are damaged in the process and that required spacing and clearances are achieved.

Unless specified otherwise, keep the sides of excavations vertical to at least 150 mm above the pipe.

Obtain written permission of the land owner prior to commencing any excavation across improved surfaces.

Adopt the most appropriate method of construction to minimise restoration of improved surfaces such as pavements, driveways, kerbs and gutters.

For open excavations across improved surfaces, keep the trench width to the minimum allowed. Saw cut neat straight lines at least 150 mm beyond the outer limits of the excavation through bitumen, asphalt and concrete. Remove pavers, blocks or brick pavements by hand, clean them and set them aside for later replacement-

11.8 Trench Excavation

11.8.1 General

Ensure that the minimum cover requirements shown on relevant Design Drawings are satisfied following any earthworks that may occur in the area of the water main.

From commencement of excavation, trenches shall be maintained in a stable condition to prevent movement or collapse. The length of trench open at any one time shall be minimised.

Ensure the trench centreline aligns with the design centreline of the pipeline within the specified tolerances.

Excavate to at least the minimum width shown on the Design Drawing(s) but not greater than that required for the ground support system. Where the minimum width is exceeded by more than 500 mm, have the structural condition of the pipeline assessed by the engineer.

Routinely monitor soil types and soil condition. Notify the relevant person (e.g. engineer, Designer, Geotechnical Specialist) of any occurrence of significant difference from the predicted soil type or conditions. Do not proceed with pipeline installation at the locations of interest until the structural design has been re-evaluated and confirmed or modified. With the exception of where a special base is required, excavate below the invert of the pipe to at least the depth shown on the Design Drawing(s) but not more than 50 mm below that depth.

11.8.2 Construction of embankment

Where compaction of the embedment material in an embankment to the required density will not be possible owing to the absence of side containment, first construct the embankment to top of the pipe embedment zone and then cut a trench for installation of the pipeline.

11.8.3 Clearances for on-site works

Where personnel will require access for welding or application of corrosion protection, provide clear space, measuring at least 500 mm in all directions from the workface.

11.9 Refill of excessive excavation

Where the excavation depth and width exceed than the approved limit, arrange for the engineer to assess the structural requirements of the pipe and provide direction on refilling the excessive excavation with one of the following:

In foundation and embedment zones:

- a) In wet sandy conditions, 20 mm single size coarse aggregate; and
- b) Elsewhere:
 - i) 20 mm Class '2' crushed rock, or;
 - ii) 3% cement stabilised 20 mm Class '2' crushed rock, or;
 - iii) C10 Grade concrete, formed or screeded to an even and uniform finishIn trench fill (backfill) zones:

Place and compact all refill (apart from concrete) to the relative compaction value specified for embedment material in trafficable or non-trafficable areas.

12 PIPE EMBEDMENT AND SUPPORT

12.1 General

Provide embedment and support of the type as specified.

Place embedment material uniformly along and around the whole length of the pipe barrel, couplings and other appurtenances in a manner to ensure uniform density of side support (including haunch support) and overlay with no distortion, dislodgment or damage to the water main.

For pipeline projections such as pipe sockets, flanges or couplings, excavate pockets in the bedding material so that the pipe is fully supported. Ensure the bedding below any projection is not less than 50% of the specified bedding depth.

12.2 Embedment Materials

12.2.1 General

Use embedment materials as specified in the Design Drawings or Specification.

The relevant Water Authority may require embedment materials to be authorised.

Single size coarse aggregates of sizes 10,14 and 18 mm are generally deemed to be “self-compacting” i.e. can achieve specified density index by rodding and/or forking when placed around a pipe, but may not provide adequate conductivity for cathodically protected steel pipelines.

12.3 Compaction of Embedment

During placement, compact embedment material in layers to uniformly support the pipe and to achieve the degree of compaction

When choosing compaction equipment, the number of passes and the thickness of layer to be compacted, take account of the material to be compacted and the pipe to be installed.

Do not employ compaction equipment or methods that produce horizontal or vertical earth pressures that may cause damage to or excessive distortion of the water main.

Do not use flooding compaction unless specifically authorised by the engineer and the Water Agency.

If flood compaction is authorised:

- a) only use in situations where embedment material and the surrounding native soils are non-cohesive and completely free draining;
- b) only use beneath non-trafficable areas where compaction trials have been undertaken and proven successful; and
- c) do not use beneath trafficable areas.

12.4 Bedding for pipes

12.4.1 Trench Floor Preparation

Inspect the trench floor for rock outcrops and soft and loose areas. Take appropriate action to ensure the pipe or fitting or valve or other appurtenance or structure will not be subject to differential settlement in the future.

Where rock outcrops are present, trim the trench floor and fill with granular material to restore the design trench floor level limits.

Compact and level all fill and all disturbed areas to not less than the density of the natural ground.

Remove all debris and water before bedding is placed.

12.4.2 Bedding and Pipe Support

Pipe bedding is the zone between the ground foundation and the bottom of the pipe. In most cases, material specified for pipe embedment is used for bedding.

Provide bedding of the type as specified.

Where the water main is supported on concrete, do not place bedding material until the concrete has obtained its initial set.

Place and rake-in the bedding to the required depth.

Compact the bedding material to the relative compaction as specified by the relevant water authority or the engineer.

Do not walk on the centreline of the compacted bedding.

Where specified, envelope the embedment material with geotextile filter fabric.

13 PIPE INSTALLATION

13.1 Installation of pipes

13.1.1 General

After preparing pipe bedding, lay and joint pipes in locations and sizes as specified. Use methods, materials, tools and equipment in accordance with manufacturers and/or supplier's instructions and recommendations, relevant Standards and requirements of this Part.

Maintain the inside of all items clean and dry during the construction of the water main. Use exclusion caps, plugs or blank flanges of a suitable design to seal open ends of items as necessary to prevent contamination during pipe laying operations.

If at any time pipes become flooded internally with dirty water during storage and/or construction, remove any dirt and foreign matter from within the pipeline.

13.1.2 Cleaning, inspection and joint preparation

Clean and examine all pipeline system items before installation. Inspect each joint seal for fit and flaws before making the joint in accordance with the manufacturer's instructions. Do not use damaged, dirty or incorrect seals. Ensure that the correct joint lubricant is used for rubber seals.

Chamfer, if required, and provide witness marks on the unmarked length of any cut pipes.

Do not score pipes when providing the witness mark.

Treat cut pipe ends in accordance with pipe manufacturer's recommendation.

13.1.3 Laying

Firmly and evenly embed the barrels on the graded and compacted bedding material.

Excavate pockets for sockets, couplings, flanges or other projections so as to ensure the pipeline is fully supported along the full length of pipe barrels. Ensure such pockets are the minimum necessary to keep the projection clear of the bedding material, except where access for joint treatment requires additional excavation.

To prevent movement, restrain pipes already laid before the next joint is made.

Lay all pipes with their identification markings facing upwards.

Lay the water main on continuously rising grades from scour valve to local high point, notwithstanding any minor irregularities in the ground surface. Make gradual changes in alignment or grade by deflecting at flexible joints after the joints have been made. Comply with the manufacturer's recommendations in respect of maximum deflection for each joint.

When joining pipes:

- a) Ensure that the inside of the socket is clean.
- b) Where elastomeric seals are required to be fitted, clean and fit the seal if not already fitted. Check that the elastomeric seal sits evenly in the housing.
- c) Apply the manufacturer's specified lubricant to the end of the spigot and chamfer of the pipe spigot.
- d) Align the pipes so that there is no deflection at the joints before inserting the spigot in the socket and pushing it home to the witness mark.
- e) Hold the socket end firmly during jointing to prevent previously assembled joints from moving.

f) Where pipes are required to be cut in the field:

- Cut the spigot end square and remove all burrs.
- Chamfer the cut end of the pipe with a taper of approximately 15° to approximately half the wall thickness, or as otherwise specified by the pipe manufacturer.
- Witness mark the pipe at the distance specified by the manufacturer and make the joint

If the same manufacturer does not make spigots and sockets, refer to the socket manufacturer for the correct witness marking depth.

If an elastomeric seal joint is located at the end of a length of restrained pipes (e.g. welded, flanged, locked joints) install anchorage/thrust restraint as specified.

If the air temperature is hotter or colder than the ground temperature, pipes will contract or expand when buried. Laying and joining pipes at the cooler time of the day may reduce stressing of the pipeline.

After laying each pipe, temporarily seal the exposed end using an exclusion cap or approved equivalent to prevent ingress of excavation debris, vermin, trench material, water and other foreign material.

13.2 Horizontal and Vertical Deflection of Pipes

13.2.1 General

Minor deflections of a pipeline may be achieved by cumulative deflections at the joint of elastomeric ring seal jointed pipes. Polyethylene (PE) pipes may be deflected by controlled bending along the length of the pipe. Limits of deflection are specified by the pipe manufacturer.

13.2.2 Deflection at a pipe joint

Make the pipeline joint in a straight line before deflecting the joint. Do not exceed the pipe manufacturer's specified maximum deflection. *The introduction of new designs of joints for plastics pipes has reduced the deflection in the joints from 3° to 1° or less.*

13.2.3 Curving of pipe

Where permitted by the Specification, cold bend the pipe with a uniform radius along the length of the pipe in accordance with the pipe manufacturer's instructions. *The bend radius (in mm) of PE pipe is not less than 25 x De, where De is the nominal external pipe size in mm*

Do not exceed the minimum bend radius specified on the Design Drawings or in the Specification. Join the pipes directly in line before making the curve. Do not use temporary pegs or stakes to restrain the pipe during curving.

13.3 Under-pressure Cut-in Connection to Pressure Pipes ≥DN 80

13.3.1 Inspection of host pipe

Remove sufficient corrosion protection material to allow the installation of the off-take fitting.

13.3.2 Inspection of valve to be installed

Inspect the valve to be installed to confirm that the obturator (wedge) can be fully withdrawn into the bonnet so that it will not be damaged during the cut-in operation.

13.3.3 Disinfection of fittings and equipment

Do not use equipment that has been used in sewer applications without washing to remove all surface deposits with a pressurised washing system using clean water and a biodegradable detergent.

Disinfect all connection fittings and equipment prior to installation / use by either of the following methods:

- a) Spray or flood all surfaces with a solution of sodium hypochlorite of concentration not less than 1%; or

NOTE: This solution may be corrosive to some components.

- b) Spray or flood all surfaces with an 80/20 alcohol (ethanol)/ water solution.

13.3.4 Installation of the valve

Install valves in the vertical position, unless authorised by the relevant Water Authority

Install and test the valve as follows:

- a) Inspect the valve for damage. Repair any damage to the external coating as directed by the Water Agency. Reject valves with damage to the coating of the waterway.
- b) Check the valve and off-take clamp flanges to ensure the sleeves fit in the bolt holes. Trim insulation sleeves such that they join inside one flange, and not at the flange joint.
- c) Exercise the valve and verify the correct spindle operating direction.
- d) Disinfect the valve and clamp.
- e) Bolt the valve to the flanged off-take clamp using an authorised gasket and bolting system.
- f) Tighten bolts.
- g) Support (using concrete blocks or other approved support) the valve and the flanged off-take and secure to ensure no mechanical load is transferred to the flanged off-take clamp or host pipe.
- h) Test degree and integrity of the electrical resistance of the bolted joints.

13.3.5 Cut-in operation

Cut-in (drill) the host pipe as follows:

- a) Prior to commencing the cut-in (drilling) operation fit the appropriate hole saw (cutter) and pilot drill for the pipe material to the under pressure cut-in connection machine.
- b) Lower the under pressure cut-in connection equipment safely into the excavation and assemble onto the valve.
- c) Pressure test the off-take clamp assembly on the host pipe
- d) After satisfactory pressure testing, proceed with the under pressure cut-in connection operation until the pipe coupon (removed section) actually separates from the pipe thus ensuring that is retained by the cutter.
- e) When the hole has been drilled remove / drain the swarf out of the machine.
- f) For holes 80–150 mm in metal pipes, position a plastics insert in the host pipe to isolate the exposed metal surface created during the cut-in process so as to limit tuberculation (corrosion nodules which grow and restrict the flow).
- g) Close the valve.
- h) Once the under-pressure cut-in connection equipment has been removed, check the assembly for visible leaks.

13.4 Flootation Control

Prevent flotation of pipes by:

- a) Using concrete bulkheads or trench stops in accordance with Design Drawing(s) and/or
- a) Placing and compacting sufficient height of fill material; and/or
- b) Filling the pipeline with water, where authorised; and/or
- c) Other appropriate method authorised by the engineer.

13.5 Thrust and Anchor Blocks and Restrained Joints

Construct thrust or anchor blocks at valves, flexibly jointed bends, tees, enlargers, ends of PE pipelines and reducers of the type and size indicated in the relevant Design Drawings.

Position thrust and anchor blocks to bear against undisturbed material in the direction of the thrust and over the specified bearing area and to allow for movement at the joint, caused by pressure surges, ground movement etc. Do not encase any part of joints.

Place an approved membrane (e.g. PE or PVC or felt) between the fitting and the concrete to prevent damage to the coating of the fitting. Ensure that thrust and anchor blocks are properly formed up before concrete is poured.

Since thrust acts through the centre of the fitting, construct thrust and anchor blocks equally about the centre of the fitting. It is important to note that it is the bearing area that is critical and NOT the weight or volume of concrete used in the thrust block.

Ensure that anchorage does not interfere with other services.

Where poor bearing capacity of the soil and/or the possibility of the area being disturbed in the future is encountered, refer to the engineer for alternative methods of providing thrust restraint. Restrained joint arrangements may be employed. Restrained joint systems include welded joints, flanged pipes and fittings and commercial mechanical restrained joint systems.

Where restrained joints are specified for ductile iron pipelines, obtain written installation procedures from the manufacturer before installation. Adhere to the manufacturer's installation procedures.

13.6 Tapping of Mains, Property Services and Water Meters

In all instances where tapping is employed:

- a) tap with the main dry before completing embedment and placement of trench fill and hydrostatic pressure testing;
- b) tap curved mains, where curving of pipe is permitted (e.g. PE) at the crown of the pipe;
- c) maintain a minimum spacing of 500 mm between tapings, and from a tapping and the end of a pipe; and
- d) remove all swarf before making the connection.

In addition to (a), (b), (c) and (d), for PE mains:

- i) where electrofusion tapping saddles are used allow the assembly to cool naturally in accordance with the manufacturer's instructions before tapping;
- ii) where under pressure tapping is performed, use tapping equipment that employs a plug cutter that can retain the PE pipe wall plug within the cutter; and
- iii) where dry tapping is performed, use a plug cutter.

Tapping at the side of a straight pipe section of main is permitted.

Record and advise the location of all service connections, property services and ducts to the Designer for recording on the As-built drawing plan.

Install appropriately sized ball valves on property services at predetermined locations on mains as they are being laid.

13.7 Marking Tapes

Lay marking tape for mains and property services in accordance with the Design Drawings Fix and join marking tapes in accordance with the Design Drawings and/or Specification.

13.7.1 Non-detectable marking tape

Lay non-detectable marking tape on top of the pipe embedment material before trench filling.

13.7.2 Detectable marking tape

When detectable tape is specified, lay tape on top of the pipe embedment. Lay the tape over the embedment to form a continuous connection between valves and/or hydrants. Strip the ends of the tape to expose its conducting wires.

13.8 Scours

Construct gravity and pumped scours of the type, size and locations shown in the Design Drawings.

13.9 Flanged Joints

Connect flanged joints in accordance with Design Drawing(s) using specified gaskets or O-rings and bolting.

When installing pipes containing screwed flanges, take care to prevent cracking of the thread sealant. At all times during installation and prior to inserting the bolts, ensure that the matching pipe and valve/fitting are fully supported. Tighten bolts in the sequence nominated in the Design Drawing(s). Use a torque wrench to achieve the nominated tightening torque.

For PE pipelines use a butt welded PE stub flange / adaptor with a Grade 316 Stainless Steel backing ring conforming requirements of the Specification.

Refer to figure 21 for a typical diagram for PE stub flange, backing ring and assembly.



Figure 21: PE STUB FLANGE, SS316 BACKING RING AND FLANGE ASSEMBLY

14 TRENCH BACKFILL

14.1 Trench Backfill

Placement and compaction of trench backfill is critical to avoiding subsidence over or near the trench and consequent damage to pavements and structures.

14.1.1 Material requirements

14.1.1.1 Trafficable Areas

Where the filled trench will be subjected to traffic loading, ensure the fill material complies with the road Owner's specifications or the relevant Water Authority nominated specifications. In the absence of a directive, obtain approval to use one of the following:

- a) For trenches in trafficable areas other than footways less than 1.5 m deep, 20 mm Class 2 plant mixed wet mix crushed rock, for the full depth or a suitable equivalent;
- b) For trenches in trafficable areas other than footways that are 1.5 m deep or greater:
 - i) 20 mm Class 2 plant mixed wet mix crushed rock for the top 600 mm; or
 - ii) 20 mm Class 4 (or better) crushed rock for the remainder, or other trench fill material specifically approved by the road Owner.
- c) For trenches under trafficable footpaths/cycleways, 20 mm Class 4 (or better) crushed rock, or other trench fill material specifically approved by the Road Owner.

14.1.1.2 Non-Trafficable Areas

Use a trench fill material complying with the Specification.

Where well-graded granular materials (e.g. crushed rock) are specified, seek guidance from the engineer in relation to moisture conditioning.

If the Specification permits excavated material to be used as trench fill, ensure it is free of organic material and that it contains no rock or hard clay greater than 75 mm and that it can be compacted to the required degree of compaction.

Where excavated material is a non-cohesive soil (e.g. clean sand, silty sand and poorly graded sand and gravel mixtures) use only in those areas where the natural soils within which works are being undertaken are also non-cohesive.

Where non-cohesive soil fill is proposed in areas where the natural soils are cohesive (e.g. clayey) do not use unless approved by the Designer, in which case comply with any additional requirements for placement and compaction.

14.1.2 Compaction of trench fill

Ensure trench fill compaction satisfies the requirements of BS 1377-2:1990 *Methods of test for soils for civil engineering purposes. Classification tests*, for different materials (i.e. non-cohesive / granular or cohesive) for Trafficable and Non-trafficable areas.

Relevant 'density index' and 'dry density ratio' have to be referred from ISO 11266:1994.

NOTES:

Single size coarse aggregates of sizes 10, 14 & 18 mm shall be deemed "self-compacting" and do not require compaction testing when used for pipe embedment

1. The relevant Road Transport Authority may specify alternative values for trafficable areas
2. Degree of compaction of the trench fill in trafficable areas depends on:
 - a). the backfill zone – higher degree of compaction is required in the zones closer to the surface; and
 - b). the road type – Major highway and roads carrying greater loads require higher degrees of compaction.
3. Specification of an alternative degree of compaction of the trench fill in non-trafficable areas depends on the site requirements.
4. Compaction shall be to the degree specified in the project Specification.
5. Graded gravels and sands having fines (silts and clays) greater than 5% have their compaction determined by dry density ratio.

Compact trench fill material in layers to achieve the required density uniformly throughout the depth of each layer.

Do not commence mechanical compaction of fill material directly above the pipe until the total depth of cover above the pipe is adequate to prevent damage to the main.

14.2 Embankment Fill

Where the design requires filling or construction of an embankment, undertake in accordance with the Design Drawings and/or Specification.

Consult engineer to ascertain if supervision is required by the geotechnical specialist (Designer).

Where filling or construction of an embankment is required and is not defined in the Design Drawings and/or Specification, consult the Designer to provide:

- a) the degree of clearing required to establish an embankment foundation;
- b) the level of compaction of embankment fill material required;
- c) the preferred method of placement and compaction;
- d) any placement and/or compaction limitations over the top of the pipeline; and
- e) any special conditions associated with placement and/or compaction of the remainder of the fill in layers.

Section 3 – Pipeline Cleaning and Acceptance

15 SWABBING

15.1 General

The relevant water authority may ask the contractor to swab the pipelines under the supervision of the implementing agency, if:

- a) there is evidence that pipes and/or fittings are contaminated with dirt or other foreign material; and/or
- b) the main was flooded during construction; and/or
- c) the main fails bacteriological testing

15.2 Swabs

A swab is typically a section of foam that is inserted into the water main and using the flow of water, pushed towards a discharge point, forcing deleterious material from the system.

Store and handle swabs hygienically.

Use at least two swabs for each swab run.

Insert swabs during construction into the main at connection point(s) of new mains to existing mains or into previously swabbed new mains.

For DN 100 to DN 150 mains inclusive, swabs may be inserted at hydrants.

15.3 Swabbing Procedure

Use the following swabbing procedure for each swab run:

- a) Number all swabs and record where they are inserted into the main.
- b) Insert swabs using a clean plunger.
- c) Isolate the length of water main subject to swabbing by closing appropriate valves, including valves on off-take mains, gate valves on copper and polyethylene sub-mains and large size service connections where applicable. Close all hydrants within the limits of the swab run. Carry out swab runs prior to charging and flushing the main(s).
- d) Operate the controlling valve to propel the swab along the water main swab route at a velocity of between 0.5 and 1.0 m/s.
- e) This velocity can generally be achieved by opening the controlling valve approximately 1½ to 2½ turns for DN 100 to DN 150 mains or 2 to 4 turns for larger mains.
- f) Upon removal of the swabs, flush the main until the discharged water is clear and then close the controlling valve.
- g) Repeat procedures (b) to (e) using new clean swabs as directed by the engineer if a large amount of debris is discharged or if after a reasonable flushing time the discharging water remains discoloured.
- h) Record the number of each swab as it leaves the main to ensure that none are left in the main.
- i) Only remove the discharge assembly when it is sure that entry into the main of deleterious matter or discharged water has been prevented and the results of bacteriological testing are satisfactory
- j) Dispose of swabbing wastewater in accordance with the relevant requirements.

16 ACCEPTANCE TESTING

16.1 General

Acceptance testing is required to test the capability of the pipeline assembly to satisfy design requirements as specified. It is not intended to test the material capability. Testing is intended to:

- a) Reveal the existence of any assembly and structural faults.
- b) Ensure the water main can sustain pressures greater than the maximum operating pressure without leakage.
- c) For open trench construction, confirm the success of placement and compaction of pipe embedment and trench fill, design and placement of thrust and anchor blocks and installation of pipeline components.
- d) Ensure that the pipeline is not contaminated.

Undertake acceptance testing of all water mains and structures in accordance with the Specification and in the following order:

- a) Visual inspection.
- b) Hydrostatic pressure testing.
- c) Water quality testing.

Where specified, clean pipes, fittings and structures before any test is performed.

Unless otherwise permitted by the relevant Water Authority, arrange testing by an ISO Certified Recognised Testing Laboratory.

If any of the tests prove to be unsatisfactory, detect and rectify the fault. Continue to rectify and retest the water main, property service, connection, joint etc. until a satisfactory test result is obtained. Even if testing produces satisfactory results, rectify any water main, property service, connection, joint, structure or appurtenance that has a visible or detectable leak, blockage, malfunction or other defect.

16.2 Visual Inspection

Visually inspect all water mains and their component markers to ensure the pipeline assembly and the type and location of markers are as specified.

Verify by inspection of purchasing records and/or visual examination that all products and materials used are approved by the relevant Water Authority.

16.3 Hydrostatic Pressure Testing

16.3.1 General

Use calibrated gauges that are controlled under the operator's or testing contractor's QA system for pressure testing.

Use mains water or other disinfected water for pressure testing.

16.3.2 Mains

If any of the test results are unsatisfactory, detect and rectify the fault and re-test. Rectify any water main in which there is a visible or detectable leak or blockage.

Test procedure should be carried out according best practice in consultation with the relevant water authority. Unless otherwise permitted by the engineer, adopt a maximum test length of 1000 m.

Acceptance testing may be conducted progressively with the authorisation of the engineer. Testing may be carried out as soon as the Works are completed and where concrete thrust restraint curing times have lapsed.

Where isolation is available, the water main may be progressively tested in sections of at least 100 m, or in its entirety if the main is less than 100 m.

Visual detection of leaks may be adversely affected by wet weather.

16.4 Water Quality Testing

16.4.1 General

It is compulsory for all new mains to pass bacteriological tests. In consultation with the water authority, A Water Safety plan (WSP) should be developed by all water supply operator or system. The National WSP provided by the water authority should be referenced and where possible, with the approval of the water authority, develop a WSP from accepted best practice.

Disinfection of drinking and non-drinking water mains may be required to ensure suitable water quality parameters are maintained and to pass bacteriological tests. Disinfection may also be required where there is a likelihood of contamination.

Conduct a bacteriological test on all new mains following satisfactory completion of swabbing/flushing and pressure testing of the water main.

16.4.2 Test procedure

Conduct a bacteriological test on all new mains following satisfactory completion of swabbing/flushing and pressure testing of the water main as follows:

- a) Scour past the sampling point.
- b) Engage a Recognised Testing Laboratory accredited for the test to collect representative water samples from the test section of the water main.
- c) Dispose of testing water in accordance with the relevant environmental Regulator and/or the relevant Water Authority requirements.

16.4.3 Failure of test

For failed sections of water main, swab, flush and/or disinfect the main and then re-test.

Rework until all test results are satisfactory.

17 DISINFECTION

17.1 Application

Following a satisfactory hydrostatic pressure test and where required by the Specification or engineer, disinfect all the following drinking water mains by adding a disinfectant to the water drawn from the water distribution system as follows:

- a) New water mains (except where an exemption has been granted, by the relevant Water Authority, for mains of particular diameters) before they are placed in service even if the new main will not be providing water to properties immediately after being placed in service.
- b) Existing water mains that are taken out of service during construction.
- c) Renewed, including relined, water mains (except where an exemption has been granted, by the relevant Water Authority, for mains of particular diameters).

Disinfect shall be in accordance with the relevant water utilities procedures for disinfecting new mains.

Where it is not practicable to disinfect pipes, fittings and appurtenances used to connect an existing water main to a new water main, clean each connecting item and spray or swab with a 1% solution (1% of free chlorine in ppm) immediately before installation.

During the disinfection process:

- a) Operate all valves, hydrants, water meter ball valves (where fitted) and other fittings to ensure complete disinfection.
- b) Take measures to protect the environment.

When using, handling and storing disinfecting agents comply with the applicable occupational health and safety legislation, regulations and requirements.

17.2 Flushing of Disinfection Water

Flush the mains and service pipelines until the disinfectant concentration does not exceed 1.0 mg/L in the disinfected mains or until the concentration does not exceed existing main's disinfectant background level.

Take all necessary steps to ensure that disinfected water used in the disinfection process does not enter the parts of the distribution system already in service.

Scour and flush mains at the earliest opportunity following the required minimum contact period.

Caution: *Excessive periods of contact with standing dose concentrations of disinfectant may affect future material performance of materials such as elastomers (e.g. pipe seals and resilient seated valves). Taste and odour problems may be experienced when the main is put into service.*

Dispose of disinfected wastewater to meet relevant Regulator and the relevant Water Authority requirements.

ANNEXES

ANNEX 1 – LIST OF REVIEWERS

GVWC
SALWACO
Decentralized water Service provider
Ministry of Health and Sanitation
Representative from the Contractors (SLIE)
Representative from Consulting Firms (SLIE)
Large Customers
NWRMA
Ministry of Water Resources
National Fire force
Ministry of Justice
Fourah Bay College (Civil Engineering Department)
Sierra Leone Standards Bureau
Consumer Protection Agency
Ministry of Works
Sierra Leone Roads Authority
Ministry of Lands (Planning)
Local Government
Freetown City Council (FCC)
Ministry of Environment
Environment Protection Agency (EPA)
Packaged Water Representative
SLEWRC
MCCU
WASHNET

ANNEX 2 – DEFINITIONS & GLOSSARY

Term	Definition
Access Chamber	An in-ground structure including a cover constructed in the line of a water main to facilitate operation, testing and/or maintenance of the system. It will generally contain appurtenances such as valves
Access Cover	A removable cover that is installed at or above finished surface level on an access chamber to allow access to appurtenances
Aggressive Soil	Soil which could have a corrosive or other adverse effect on a pipeline component and which requires special consideration with respect to protective measures. See also <i>contaminated soil</i>
Alignment Of Mains	Positioning of mains relative to locations such as property boundaries or the Water Agency's space allocation in the road reserve
Allotment	See <i>lot</i>
Allowable Horizontal Bearing Pressure	The maximum permissible pressure on foundation ground that provides adequate safety against rupture of the ground mass or movement of the foundation of such magnitude as to impair the structure that imposes the pressure
Allowable Operating Pressure, AOP	Maximum pressure at which a piping system can sustain in continuous use under given service conditions without pressure surge. For plastics piping systems the value is specified at a temperature of 20°C
Appurtenance	A component of a pipeline such as a fitting, valve, hydrant, etc.
Authorised	Acceptable to, authorised by or approved by the Water Agency or Owner or Regulator
Average Day Demand	The total water demand per year for a given area or category of development divided by 365
Backfill	Material (including embedment and trench fill) and procedure used to fill an excavation. See also <i>engineered fill</i>
Balancing Storage	See <i>operating storage</i>
Bedding	Zone between the foundation and the bottom of a pipeline. See also <i>embedment</i>
Blue	A colour defined in accordance with RAL ¹ DESIGN colour numbers as being no darker than 200 80 25 or 210 80 25 and no lighter than 200 90 10 or 210 90 10, respectively NOTES: ¹ RAL Deutsches Institut für Gütesicherung und Kennzeichnung e.V. (RAL German Institute for Quality Assurance and Certification) Siegburger Straße

	<p>39</p> <p>D-53757 Sankt Augustin</p> <p>Telephone: +49(0)2241/1605-30</p> <p>Telefax: +49(0)2241/1605-16</p> <p>http://www.ral.de/farben/en/farbvorlagen/index.html?content1.shtml</p>
Boring	A method of machine excavation working from a shaft or pit and creating a cylindrical tunnel slightly larger than the pipeline
Boundary	Survey line separating adjoining properties for the purposes of defining ownership/title
Bulkhead	A structural partition across a pipeline trench, built to minimise longitudinal and lateral movement of the pipeline, to minimise ground movement in the trench, and to restrict movement of fines within and along the trench caused by infiltration and ground water flow through the embedment and trench fill materials
Cathodic Protection	Partial or complete protection of a metal from corrosion by making it the cathode, using either galvanic or impressed current. It is usually applied to mitigate external corrosion of electrically continuous welded steel buried pipelines and internal corrosion of welded steel service reservoirs
Carriageway	Portion of a road or bridge assigned to the movement of vehicles, inclusive of any shoulders and auxiliary lanes. It is designated as that part of a public road (way) between kerbs. See also <i>local road, major road, road, road reserve, trafficable area</i>
Coating	Additional organic or inorganic material applied to the internal and/or external surface of a pipeline component at a specified film thickness, which is intended to provide long-term protection from corrosion, mechanical damage and/or chemical attack. Such coatings require special surface preparation and application techniques. See also <i>lining</i>
Concept Plan	A package of information provided to the designer by the Water Agency to enable the appropriate planning / design of major water system components to be performed
Constructor	An individual, corporation or legal entity including any contractors and sub-contractors that is accountable at law for delivery of Works under a specific contract or development agreement
Contaminated Soil	Soil that has been affected by previous land use or by direct or indirect infiltration of chemicals or other substances such that it requires special consideration. See also <i>aggressive soil</i>
Controlled Fill	See <i>engineered fill</i>
Control Valve	A valve designed to alter flow and pressure in the pipework on either side of the control valve to achieve the required operational outcomes

Corrosion	Deterioration of a material and alteration of its properties due to chemical or electrochemical reaction between the material and its environment
Dead Water	Water that is not useable. For example, water below the outlet level of a reservoir or tank
Demand	Volume of water used by customers during a certain time interval from a water supply system
Demand Forecasting	Process of anticipating volumes of water required to meet customers' peak (maximum) hourly, daily and annual requirements
Design Drawings	Plans and drawings required for the construction of the water supply transfer, distribution or reticulation systems and showing the locality including roads and water main details, the site plan including lots, boundaries, roads, proposed and existing water mains, proposed property services, drains, watercourses, site contours, proposed aqueducts, proposed boreholes, a level schedule or longitudinal elevation if the water main is to be constructed prior to road or drainage construction and construction details. Supplementary information may include proposed buildings, existing services and groundwater and watercourse levels
Design Period	Period of time a design analysis should cover in order to size system facilities (such as service reservoirs, pumping stations and water filtration plants). It is the number of consecutive days that the daily demand factor exceeds the ratio of supply (or input) capacity to maximum day demand
Design Pressures, DP	<p>Limiting pressures, both maximum and minimum, that the designer allows for in the design of a pipeline system. These pressures are used to determine as applicable:</p> <p>For the pipes network arrangement:</p> <p>(a) the extent of the proposed development that may be serviced, in terms of elevation (acceptable range of residual pressures) and distance (acceptable minimum residual pressure after headlosses);</p> <p>or, for the pipeline components, with the application of suitable factors of safety, or adoption of a default pressure:</p> <p>(b) a suitable pipe material to meet expected operating pressures for the duration of the system life; and</p> <p>(c) structural requirements associated with the pipeline pressure</p>
Designer	Person(s) or firm responsible for a design output. Such person or firm may be accountable to a Project Manager or other person having responsibility under a contract or otherwise
Developer	A person, organisation, local government authority or government authority (other than the Water Agency) responsible for provision of a water supply scheme or water reticulation system

Direct Tapping	A procedure consisting of drilling and tapping the pipe wall followed by insertion of a tapping valve/maintap
Diurnal Pressure Variation	A daily variation in system pressure, at any location, between periods of high and low water usage (normally between day and night)
Distribution Main	A water main serving as the principal distributor within the supply area, normally without direct consumer connections
Distribution Network	A combination (network) of larger diameter water mains necessary to ensure an adequate supply of water to, and within, reticulation networks (systems)
Drinking Water	According to the World Health Organization's 2017 report, safe drinking-water is water that "does not represent any significant risk to health over a lifetime of consumption, including different sensitivities that may occur between life stages".
Dynamic Pressure Head	When a pump is operating, vertical distance from a reference point (such as a pump centre line) to the hydraulic grade line
Embankment Fill	Fill material placed over the overlay for the purpose of creating an embankment
Embedment	Zones around a pipe between the foundation, the trench or embankment fill and the trench walls. See <i>bedding, haunch support, side support</i> and <i>overlay</i>
End Of Pipe	A termination of a pipeline with no provision for access from the surface.
Existing Surface Level	Undisturbed ground surface, prior to adjustment as part of the development works
Fatigue De-Rating	An allowance made, during the design process, for the reduced pressure withstanding capability of products (particularly plastics) as a result of anticipated cyclic loadings within the system
Ferrule	A component used to connect a service pipe to a main, usually capable of shutting off the flow of water to the service pipe. Also known as a maintap
Finished Surface	Paved or unpaved surface of a filled trench or an embankment
Finished Surface Level, FSL	Ground level at the completion of construction and landscaping
Fire Flow Demand	Quantity of water required for firefighting purposes often expressed as a flow rate for a particular time period or from particular locations in the water supply system
Fitting	A component of a pipeline, other than a pipe, which allows pipeline deviation, change of direction or bore. In addition, valves, flanged-socketed pieces, flanged-spigot pieces, collars and couplings are also defined as fittings
Flexible Joint	A joint that permits limited, defined angular deflection, both during and after installation, and which can accept a slight offset

	to the centreline
Flexible Pipe	A pipe that relies primarily upon side support to resist vertical loads without excessive deformation. Flexible pipe materials include PVC-U, PE, steel and ductile iron
Flushing Point	A specially designed flushing assembly, hydrant or scour
Footpath	A formed pavement for pedestrians, especially one at the side of a road in the footway. See also <i>footway</i>
Footway	A strip of land between the front boundary of a lot and the kerb or carriageway. It can include a footpath and is also known as nature strip (where it is not paved) or verge in some regions of Australia. See also <i>carriageway</i>
Foundation	A naturally occurring or replaced material beneath the bedding
Gravity System	A system wherein flow and/or pressure are caused by the force of gravity. There are two kinds of such systems: <ul style="list-style-type: none"> • Pressurised gravity system, where the pipeline operates full; and • Non-pressurised gravity system ,where the pipeline operates partially full
Head, H	Pressure expressed in terms of the height of a column of water (in metres head). The head is a factor of 9.81 (nominally 10) lower than the equivalent value in kPa, e.g. 800 kPa \cong 80 m head
Hold Point	A point beyond which an activity may not proceed without the approval of a designated organisation or authority
Hydraulic Grade Line, HGL	A line (hydraulic profile) indicating the piezometric level of flow at all points along a conduit, open channel or stream. In pipes under pressure, each point on the hydraulic profile is an elevation expressed as the sum of the height associated with the pipe elevation and the pipe pressure (head)
Hydrostatic Pressure Testing	A procedure in which a pipeline or section of pipeline or individual pipeline appurtenance or assembly of components is pressurised using water: <ul style="list-style-type: none"> • to determine the watertightness of the pipeline or section of pipeline or individual pipeline appurtenance or assembly of components; and/or • to verify the integrity of supporting structures such as anchor and thrust blocks; and/or • for quality control purposes during construction. See <i>system test pressure</i>
Joint	A connection between the ends of two pipeline components including the means of sealing
K-Value	Colebrook-White roughness coefficient; a measure of the interior roughness of a pipe
Layout Of Main	Nominal route of a main, generally shown in terms of specific roads, reserves and/or easements
Life Cycle	consecutive and interlinked stages of a product system, from raw

		material acquisition or generation of natural resources to end of life, inclusive of any recycling or recovery activity
Lining		Additional organic or inorganic material applied to the internal surface of a pipeline component at a specified thickness, which is intended to provide long-term protection from corrosion, mechanical damage and/or chemical attack. Such linings require special surface preparation and application techniques. See also <i>coating</i>
Local Planning Authority		Local municipal council or local government body or appeals board authorised to administer or arbitrate government town planning legislation
Local Road		A road, under the control of the local government, with load restriction, or one that carries less than 50 commercial vehicles per day in each direction.
Lot		A property for which a separate title may be held or issued, and which will be serviced by the water reticulation system
Major Road		A road to which is assigned a permanent priority for traffic movement over that of other roads.
Maximum Operating Pressure, MAOP	Allowable Pressure,	Maximum hydrostatic pressure, including a nominal allowance for surge, that can be sustained, with a factor of safety, by the type or class of pipe for its estimated useful life under anticipated operating conditions with the frequency of surges less than that expected to lead to fatigue failure for that life
Maximum Demand	Day	See <i>peak day demand</i>
Maximum Pressure	Design	Maximum operating pressure of the system or of the pressure zone as fixed by the Designer, considering future developments, all other foreseeable operating conditions and including an allowance for surge
Maximum Demand	Hour	Maximum demand which a system or part of a system is required to supply in any one hour of the year (also called <i>peak hour demand</i>). It is often expressed as a daily rate
Maximum Pressure	Working	See <i>maximum allowable operating pressure</i>
Minimum Pressure	Design	Lower limiting pressure that the Designer allows for in the design of a pipeline system. This pressure is selected to ensure: Acceptable minimum residual pressure for the types of development; and Acceptable range of residual pressures (between operating pressure limits) In the selection of pipe material, transient pressures below the minimum design pressure should be taken into account
Minimum Head	Static	The height difference between the Reservoir Level (no flow hydraulic gradient) and the elevation of the highest (and nearest) point being supplied from that Reservoir. This will usually help determine the required location / elevation of the Reservoir and/or the location of the Reservoir zone boundary

	<p>Or</p> <p>The minimum required pressure (head), at zero flow, within a supply zone, being the difference between the maximum hydraulic gradient of the supply source (reservoir FSL, maximum operating HGL of a pump or maximum setting of a PRV) and the highest development/property to be supplied from that source.</p>
Minor Road	See <i>local road</i>
Network Analysis	A process of analysing a water supply system by using a computer software network modelling package. Also known as dynamic system analysis
Nominal Size, DN	An alphanumeric designation of size for components of a pipeline system, which is used for reference purposes. It comprises the letters DN followed by a dimensionless whole number, which is indirectly related to the physical size, in millimetres, of the bore or outside diameter of the end connections
Non-Revenue Water (Nrw)	Non-revenue water (NRW) is defined as water that has been produced and is "lost" before it reaches the customer. Losses can be real losses (through leaks, sometimes also referred to as physical losses) or apparent losses (for example through theft or metering inaccuracies). NRW is typically measured as the volume of water "lost" as a share of net water produced. However, it is sometimes also expressed as the volume of water "lost" per km of water distribution network per day
Offset	A distance specifying the location of the centreline of a pipeline,
Operating Pressure, OP	<p>Internal pressure that occurs at a particular time and at a particular point in a water supply system</p> <p>For gravity systems, maximum operating pressure is the full supply level of the reservoir, less the lowest ground level applicable to the pipeline, plus surge. For pumped systems, maximum operating pressure is the greater of:</p> <p>The surge HGL less the ground level, or</p> <p>The maximum pump suction HGL plus the no discharge head of the pump, less the lowest ground level.</p> <p>Minimum operating pressure is due to maximum headloss conditions i.e. minimum supply pressure to the zone combined with peak demand in the zone (maximum water velocity through the pipelines)</p>
Operating Pressure Limit	Maximum pressure to which the Water Agency will permit a pipeline of particular material and class to be subjected in service. It typically results in a de-rating of the pipe pressure class e.g. 1.2 MPa for a Class 16 pipe
Operating Storage	Amount of storage provided to accommodate diurnal fluctuations in demand and to cater for demands exceeding the maximum available inflow rate (also called <i>balancing storage</i> or equalising storage)
Overlay	Zone between the side support and either the trench fill or the embankment fill

Owner	Agency, Authority, Board, Company, Controlling Authority, Corporation, Council, Department, Individual, Regulator, Utility or other legal entity who is the owner of the asset and/or who has responsibility for the asset
Peak Day Demand	Maximum demand in any one day of the year.
Per Capita Consumption	An estimate of the water usage in a town or village, including residential, industrial and commercial, determined by dividing the total water used by the number of persons using it. It is most commonly expressed in units of litres per capita per day
Pipe	A pipeline component of uniform bore, normally straight in axis, having socket, spigot or flanged ends
Pipe Barrel	Cylindrical part of the pipe with a uniform cross section excluding socket and spigot or flanges where relevant
Pivot Point	A chlorination injection point. This assembly consists of a 20 mm tapping and gate or ball valve. It is specified on designs for mains in some cases where there is no hydrant adjacent to a valve at the point of supply
Potable Water	See <i>drinking water</i>
Pressure Creep	A tendency for pressure, which is normally controlled at a particular upper level, to rise toward a potential maximum pressure when conditions necessary for the control are reduced. Examples of this effect in pipelines are: The pressure increase when flow rates reduce to less than the usual (designed) minimum The pressure increase downstream of a PRV when the flow rate reduces to less than that required for the PRV to operate effectively
Pressure Rating	See <i>allowable operating pressure</i>
Pressure Surge	See <i>surge</i>
Pressure Testing	See <i>hydrostatic pressure testing</i>
Pressure Zone	A reticulated supply area connected to a controlled water pressure source (typically a service reservoir or tank), covering a limited area and range of elevations to enable supply within a range of minimum and maximum operating pressures
Property Service	Portion of a property water service from main to meter location. See also water service
Pumped And Gravity System	A system where gravity and pumping are used, either separately or in combination, to provide flow and/or pressure
Pumped System	A system where flow and/or pressure are provided by means of one or more pumps and where the pipe(s) operate full
Rated Pressure	See <i>allowable operating pressure</i>
Reduced Level, RL	Elevation of a point or mark related to a nominated datum (metric or imperial). It is expressed as RL's

Regulator	Entity that has the power to enforce Regulations related to the activities and responsibilities of a local government. It applies to environmental management and protection, occupational health and safety and the like
Remote Terminal Unit, RTU	An electronic hardware device used to collect, process and transmit SCADA data and signals at a site
Reserve Storage	Amount of storage provided to cater for some continuing supply in the event of a system component failure and depletion of the operating storage
Reserve Storage Level, RSL	Top level of the reserve storage
Reservoir	Bulk drinking water storage supplying to transfer and/or distribution mains A tank or similar storage supplying to a reticulation zone
Reticulation Water Main	A water main that connects a transmission or trunk main or distribution main with service pipes. Reticulation Mains are generally sized DN 75 to DN 300
Rider Main	An additional main laid parallel to a transmission or trunk main to convey water from source to the distribution network.
Rigid Pipe	A pipe that supports vertical loads primarily by virtue of its inherent resistance to bending or deformation as a ring; when rigid pipes are used, flexible joints must be used to ensure that the pipeline installation is flexible. E.g. Reinforced Concrete pipe
Right Of Way	A specified right which gives a person or persons access across certain land belonging to another person
Road	A surface devoted to public travel and movement of goods by vehicles; a road covers the entire width between opposite property boundaries in a road reserve including the road pavement, footways, cycleways (where appropriate) and verges. See also <i>trafficable area</i>
Road Reserve	Land set aside for the road pavement, footway(s) and verge(s)
Roadway	See <i>road</i>
Scada	An electronic supervisory control and data acquisition system for compiling water system operations data and enabling automatic and remote control/operation of specific facilities
Scour	An assembly of valves and fittings installed at low points in the network and used for dewatering a portion of pipeline for operational or maintenance purposes
Service Pipe	A water pipe that supplies water from the reticulation main to the consumer. The portion of the service pipe under the control of a Water Authority generally terminates at the water meter, or in the case of fire services, the isolating valve of the fire protection system
Service Pressure	Internal pressure delivered at the point of connection to a consumer's property and within the property to points of water

	use
Side Support	Embedment zone between the bottom and top of a pipe
Shared Trenching	Simultaneous installation of two or more services in one (common) trench
Socket	The end of the pipe or pipe fittings with an enlarged internal diameter for the reception of the plain or spigot end of another pipe fitting
Specification	The document detailing the work involved in the particular project in hand
Specifications	Precise standards of performance for construction work, materials and manufactured products. Specifications make it possible to express expected values when work or items are purchased or contracted for, and they provide means of determining conformance with expectations after purchase or construction
Spigot	The plain or specifically formed end of a pipe fitting for insertion in a socket or coupling to form a joint
Split Service	A service pipe that bifurcates into two services to provide on-property connection points for two properties from a single connection at the water main
Standards	(1) Documents that specify the minimum acceptable characteristics of a product or material, a test procedure, an installation method etc., issued by an organisation that develops such documents. Such standards may or may not be used as (or called) specifications (2) A set numerical limit e.g. a contaminant limit set by a regulatory agency
Static Head	When water is not moving, vertical distance from a specific point in the water/pipeline to the free water surface. See <i>dynamic pressure head</i> and <i>static pressure</i>
Static Pressure	Static head multiplied by the specific weight of water. See <i>dynamic pressure head</i> and <i>static head</i>
Street Alignment	Plan shape of the boundary between a road reserve and the adjoining lots. See also <i>road</i>
Support Type	A mode of pipe embedment
Surge	A rapid fluctuation of pressure caused by flow alteration over a short period of time
Surge Pressure	A short-duration pressure increase caused by a sudden movement of water from such causes as a directional change in flow, the starting or stopping of a pump, and opening or closing of a valve or hydrant
Superintendent	The individual appointed by the contract principal as an independent arbiter of contract directions, issues, claims and variations

EWRC Standards	Nominated Codes, Specifications and Drawings, which may include International and/or British Standard requirements for design and construction of infrastructure and the manufacture and supply of associated products and materials, and other documents prepared and published or adopted by EWRC from time to time which further set out such requirements
System	A combination of elements that together makes up a functioning water supply
System Planning	A process of examining the present, recognising trends, making projections and developing plans to ensure water supply systems have the capability to achieve agreed customer, stakeholder and regulator outcomes
System Test Pressure	Hydrostatic pressure applied to a newly laid pipeline in order to demonstrate its integrity and tightness. This pressure may be greater than the operating pressure limit of a pipeline for a relatively short duration
Temperature De-Rating	An allowance made, during the design process, for the reduced performance of products (particularly plastics) as a result of anticipated operating temperatures above 20°C within the system
Test Pressure	See system test pressure
Trafficable Area	Any area where vehicular traffic is likely, e.g. road pavement, driveways, etc.
Transmission Main	A water main that interconnects source(s), treatment works, reservoir(s) and/or supply areas, normally without direct consumer connections
Traverse Line	A survey line fixed on the ground consisting of several connected lines of known length which meet at measured angles or bearings, and used for setting out the location of a proposed water main
Trench Fill	Fill material placed over the overlay for the purpose of refilling a trench
Trench Width	The clear width between the sides of an unsupported trench or the width inside the internal faces of a trench support system
Trench Stop	A non-structural partition across a pipeline trench built to restrict movement of fines within and along the trench caused by infiltration and ground water flow through the embedment and trench fill materials
Transfer Main	The term historically used within some water Agencies for a water main designed for bulk transfer e.g. supply to or from a reservoir and/or a supply zone. The term is applied to a main, generally >DN350 and <DN750 that is not available for connection, other than in exceptional circumstances. Equivalent terms used in the Code are trunk and transmission <i>main</i>
Underground Services	Underground assets, including those owned by other authorities

	or companies, e.g. gas, telecommunications and electrical
Useable Capacity	Operating storage plus reserve storage (of a service reservoir)
Valve	A mechanical device used for stopping or regulating flow and controlling pressure e.g. gate valve, isolating valve, control valve, pressure reducing valve, air valve and hydrant
Verge	Areas between the boundaries of a road reserve and the carriageway. This term is usually applied where there are no formed footways
Washout	A hydrant (spring hydrant) installed on a washout bend (a ductile iron 90 degree socket-flange bend) used to terminate DN 100 or DN 150 mains and which can be used for firefighting purposes and operation (flushing) of the main
Water Authority	An authority, board, business, corporation, council or local government body with the responsibility for planning or defining planning requirements, for defining and authorising design requirements, for defining and authorising construction requirements and for operating and maintaining or defining operation and maintenance requirements for a water supply and/or sewerage system or systems
Water Distribution System	Part of the water supply system comprising pipelines, service reservoirs, pumping stations and other assets by which water is distributed to the consumers. It generally begins at the outlet of a water treatment works (or source, if there is no treatment) and includes the reticulation system
Water Safety Plan (WSP)	Water Safety Plans are an improved risk management tool designed to ensure the safety of drinking water through the use of a comprehensive risk assessment and risk management approach that encompasses all steps in water supply from catchment to consumer. Water safety plans are considered by the WHO as the most effective means of maintaining a safe supply of drinking water to the public. Their use should ensure that water is safe for all forms of human consumption and that it meets regulatory water standards relating to human health
Water Service	A water pipe, owned by the property owner, that supplies water from the reticulation main to the consumer. The portion of the service pipe, known as the property service, in some cases under the control of a Water Agency generally terminates at the water meter. In the case of fire services, the service includes the isolating valve of the fire protection system at the main
Water Supply System	See <i>water distribution system</i>
Water Hammer	Any sudden pressure head change in a pipe caused whenever the velocity in the pipe is changed from one steady state condition to another (commonly caused by stopping flow too rapidly). It is often characterised by pipe movement or noise. See also <i>surge pressure</i>
Working Pressure	See <i>operating pressure</i>
Work As Constructed	Documentation showing details of work as actually

(As-Built)	constructed (in contrast to Design Drawings). Also called Work As Executed (AS-built)
Works	All those Works being water mains, valves, hydrants and accessories including valve chambers and storage facilities as shown on the Design Drawings and including any part or parts of the Works

REFERENCED DOCUMENTS

The following documents are referred to in this Code.

STANDARD	TITLE
BS EN - downloadable from www.bsonline.bsi-global.com/server/index.jsp	
EN 124	Gully tops and manhole tops for vehicular and pedestrian areas. Design requirements, type testing, marking, quality control
BS 6920:2014	Suitability of non-metallic materials and products for use in contact with water intended for human consumption with regard to their effect on the quality of the water)
BS EN 12613:2001	Detectable warning tape
BS2782 (testing) BS381c (colours) BS3012 (plastics)	Non-Detectable warning tape
BS EN 545:2010	Ductile iron pipes, fittings, accessories and their joints for water pipelines. Requirements and test methods
BS EN 1092-2:1997	Flanges and their joints. Circular flanges for pipes, valves, fittings and accessories, PN designated. Cast iron flanges
BS EN 1092-1:2013	
BS 4515-2:1999	Specification for welding of steel pipelines on land and offshore - Duplex stainless steel pipelines
BS EN 107:2000	Valves for water supply. Fitness for purpose requirements and appropriate verification tests. <ul style="list-style-type: none"> • Part 1: General requirements • Part 2: Isolating valves • Part 3: Check valves • Part 4: Air valves • Part 5: Control valves • Part 6: Hydrants
BS 5493:1977	Bitumen paint or Synthetic resin base coatings or Thermal-bonded polymeric coatings shall comply with

STANDARD	TITLE
BS EN - downloadable from www.bsonline.bsi-global.com/server/index.jsp	
BS EN ISO 1452	<p>This is a five-part publication which identifies the requirements for a piping system and its components made from PVC-U.</p> <ul style="list-style-type: none"> • Part 1 General - specifies the overarching aspects of PVC-U pressure piping systems. It includes such items as definitions and characteristic of materials. • Part 2: Pipes - specifies the characteristics of solid wall pipes made from PVC-U (pipes with a socket and pipes without socket). Part 2 includes a range of pipe sizes and pressure classes, and gives requirements on colours. • Part 3: Fittings - specifies the characteristics of fittings made from PVC-U for solvent cementing and use with elastomeric ring seals. Fittings can be made by injection moulding or fabricated from pipe. It also covers PVC-U flange adapters (from PVC-U to other materials) and the corresponding flanges made from other materials. It sets out the mechanical properties of fittings including any non-plastic components, together with geometrical and marking requirements. • Part 4: Valves - specifies the characteristics of valves or valve bodies made from PVC-U for solvent cementing, elastomeric ring seal joints and flanged joints. It sets out the mechanical properties of valves including any non PVC-U components, together with geometrical and marking requirements. • Part 5: Fitness for purpose of the system - specifies the requirements for the assembled piping system (the pipes, fittings, valves and ancillaries in combination).
BS EN 1514-1:1997	Flanges and their joints. Dimensions of gaskets for PN-designated flanges. Non-metallic flat gaskets with or without inserts
BS 1377-2:1990	Methods of test for soils for civil engineering purposes. Classification tests, for different materials (i.e. non-cohesive / granular or cohesive) for Trafficable and Non-trafficable areas
IGN 4-01-03 October 2015 Issue 2	<p>UK Water Industry Information & Guidance Note – Guide to pressure testing of pressure pipes and fittings for use by Public Water Suppliers</p> <p>IGN 4-01-03 https://www.water.org.uk/publications/WIS-IGN/general</p>
IGN 4-37-02	UK Water Industry Information & Guidance Note – Design against surge and fatigue conditions for thermoplastic pipes
American Standard NSF/ANSI 61:	Drinking Water System Components – Health Effects
NJUG 4	Identification of small buried mains & services
NJUG 7	Recommended positioning of utilities
NJUG 9	Guidelines on positioning & colour coding of utilities
ISO 2531:2009	Ductile iron pipes, fittings, accessories and their joints for water applications
POP007	Metal backing flanges for use with polyethylene (PE) pipe flange adaptors
STANDARD	DETAIL

ISO 7005-3:1988	METALLIC FLANGES — PART 3: COPPER ALLOY AND COMPOSITE FLANGES
ISO 7005-2:1988	METALLIC FLANGES — PART 2: CAST IRON FLANGES
ISO 7005-1:2011	PIPE FLANGES — PART 1: STEEL FLANGES FOR INDUSTRIAL AND GENERAL SERVICE PIPING SYSTEMS
ISO 7483:1991	DIMENSIONS OF GASKETS FOR USE WITH FLANGES TO ISO 7005
ISO 657-15:1980	HOT-ROLLED STEEL SECTIONS — PART 15: SLOPING FLANGE BEAM SECTIONS (METRIC SERIES) — DIMENSIONS AND SECTIONAL PROPERTIES
ISO 4427-2:2019	PLASTICS PIPING SYSTEMS FOR WATER SUPPLY, AND FOR DRAINAGE AND SEWERAGE UNDER PRESSURE — POLYETHYLENE (PE) — PART 2: PIPES
ISO 1452-1:2009	PLASTICS PIPING SYSTEMS FOR WATER SUPPLY AND FOR BURIED AND ABOVE-GROUND DRAINAGE AND SEWERAGE UNDER PRESSURE — UNPLASTICIZED POLY (VINYL CHLORIDE) (PVC-U) — PART 1: GENERAL
ISO 1452-2:2009	PLASTICS PIPING SYSTEMS FOR WATER SUPPLY AND FOR BURIED AND ABOVE-GROUND DRAINAGE AND SEWERAGE UNDER PRESSURE — UNPLASTICIZED POLY (VINYL CHLORIDE) (PVC-U) — PART 2: PIPES
ISO 1452-5:2009	PLASTICS PIPING SYSTEMS FOR WATER SUPPLY AND FOR BURIED AND ABOVE-GROUND DRAINAGE AND SEWERAGE UNDER PRESSURE — UNPLASTICIZED POLY (VINYL CHLORIDE) (PVC-U) — PART 5: FITNESS FOR PURPOSE OF THE SYSTEM
ISO 1452-4:2009	PLASTICS PIPING SYSTEMS FOR WATER SUPPLY AND FOR BURIED AND ABOVE-GROUND DRAINAGE AND SEWERAGE UNDER PRESSURE — UNPLASTICIZED POLY (VINYL CHLORIDE) (PVC-U) — PART 4: VALVES
ISO 1452-3:2009	PLASTICS PIPING SYSTEMS FOR WATER SUPPLY AND FOR BURIED AND ABOVE-GROUND DRAINAGE AND SEWERAGE UNDER PRESSURE — UNPLASTICIZED POLY (VINYL CHLORIDE) (PVC-U) — PART 3: FITTINGS
ISO 2531:2009	DUCTILE IRON PIPES, FITTINGS, ACCESSORIES AND THEIR JOINTS FOR WATER APPLICATIONS
ISO 9349:2017	DUCTILE IRON PIPES, FITTINGS, ACCESSORIES AND THEIR JOINTS — THERMAL PREINSULATED PRODUCTS
ISO 16139:2006	INDUSTRIAL VALVES — GATE VALVES OF THERMOPLASTICS MATERIALS
ISO 16136:2006	INDUSTRIAL VALVES — BUTTERFLY VALVES OF THERMOPLASTICS MATERIALS
ISO 2531:2009	DUCTILE IRON PIPES, FITTINGS, ACCESSORIES AND THEIR JOINTS FOR WATER APPLICATIONS
ISO 8180:2020	DUCTILE IRON PIPELINES — POLYETHYLENE SLEEVING FOR SITE APPLICATION
ISO 15853:1999	THERMOPLASTICS MATERIALS — PREPARATION OF TUBULAR TEST PIECES FOR THE DETERMINATION OF THE HYDROSTATIC STRENGTH OF MATERIALS USED FOR INJECTION MOULDING
ISO 12162:2009	THERMOPLASTICS MATERIALS FOR PIPES AND FITTINGS FOR PRESSURE APPLICATIONS — CLASSIFICATION, DESIGNATION AND DESIGN COEFFICIENT
ISO 3834-1:2005	QUALITY REQUIREMENTS FOR FUSION WELDING OF METALLIC MATERIALS — PART 1: CRITERIA FOR THE SELECTION OF THE APPROPRIATE LEVEL OF QUALITY REQUIREMENTS

ISO 3834-2:2005	QUALITY REQUIREMENTS FOR FUSION WELDING OF METALLIC MATERIALS — PART 2: COMPREHENSIVE QUALITY REQUIREMENTS
ISO 3834-3:2005	QUALITY REQUIREMENTS FOR FUSION WELDING OF METALLIC MATERIALS — PART 3: STANDARD QUALITY REQUIREMENTS
ISO 3834-4:2005	QUALITY REQUIREMENTS FOR FUSION WELDING OF METALLIC MATERIALS — PART 4: ELEMENTARY QUALITY REQUIREMENTS
ISO 4439:1979	UNPLASTICIZED POLYVINYL CHLORIDE (PVC) PIPES AND FITTINGS – DETERMINATION AND SPECIFICATION OF DENSITY.
WGS 84, 28 and 29	
BS 6920: 2004	Suitability of non-metallic materials and products for use in contact with water intended for human consumption with regard to their effect on the quality of the water)
BS EN 12613: 2001	Detectable warning tape
BS 2782 (testing)	Non-Detectable warning tape
BS 381c (colours)	Non-Detectable warning tape
BS 3012 (plastics)	Non-Detectable warning tape
NJUG 4	Identification of small buried mains & services
NJUG 7	Recommended positioning of utilities
NJUG 9	Guidelines on positioning & colour coding of utilities
WSA 01: 2004	
POP 007	Metal backing flanges for use with polyethylene (PE) pipe flange adaptors
BS EN 13636: 2004	
BS EN 1074.1 & 2: 2000	Valves for water supply. Fitness for purpose requirements and appropriate verification tests. <ul style="list-style-type: none"> • Part 1: General requirements • Part 2: Isolating valves • Part 3: Check valves • Part 4: Air valves • Part 5: Control valves Part 6: Hydrants
BS 5493: 1977	Bitumen paint or Synthetic resin base coatings or Thermal-bonded polymeric coatings shall comply with

REFERENCES

1. Allouche, E. and G. Shanghai. 2008. "The Design and Performance of Pressure Pipe Liners under Static and Cyclical Loading." Proceedings of the American Society of Civil Engineers (ASCE) Annual Pipelines Conference: Maximizing Performance of Our Pipeline Infrastructure, Atlanta, Georgia, July 22-27, 2008.
2. American Public Health Association (1960) Standard methods for the examination of water and wastewater, 11th ed., New York, N.Y.
3. Ampiah, N., A. Fam, and I. Moore. 2008. "Wavy Imperfections and the Strength of Cast-In-Place Pressure Pipe Liners." Proceedings of the ASCE Annual Pipelines Conference: Maximizing Performance of Our Pipeline Infrastructure, Atlanta, Georgia, July 22-27, 2008.
4. APIC/CEFIC: "How to do – an interpretation of ICH Q7a", published 2002
5. Bartram J. Drinking water supply surveillance. Guildford, England, Robens Institute of Health and Safety, University of Surrey, 1990.
6. Beecher, J. A. 2002. The infrastructure gap: myth, reality, and strategies. *In: Assessing the Future: Water Utility Infrastructure Management*. D. M. Hughes (ed.). Denver, CO: AWWA.
7. Brandt, M., J. Clement, J. Powell, R. Casey, D. Holt, N. Harris, and C. T. Ta. 2004. Managing Distribution Retention Time to Improve Water Quality-Phase I. Denver CO: AwwaRF.
8. CEFIC: "ISO 9001: 2000 CEFIC Guidelines for use by the chemical industry", published March 2001
9. Disinfection of rural and small-community water supplies: a manual for design and operation. Medmenham, England, Water Research Centre, 1989.
10. Edwards, M., D. Bosch, G. V. Loganathan, and A. M. Dietrich. 2003. The Future Challenge of Controlling Distribution System Water Quality and Protecting Plumbing Infrastructure: Focusing on Consumers. Proceedings of the IWA Leading Edge Conference in Noordwijk, Netherlands.
11. EN ISO 9000: 2000 "Quality Management Systems – Fundamentals and vocabulary", published December 2000
12. EN ISO 9001: 2000 "Quality Management Systems – Requirements", published December 2000
13. EN ISO 9004: 2000 "Quality Management Systems – Guidelines for performance improvements", published December 2000
14. England and Wales, Ministry of Health & Ministry of Housing and Local Government (19S6) The bacteriological examination of water supplies, 3rd ed., London (Reports on Public Health and Medical Subjects, No. 71)
15. EPA. 2000. National primary drinking water regulations for lead and copper: final rule. Federal Register 65:1950. Washington, DC: EPA.
16. Foster S, Venura M, Hirata R. Groundwater pollution. Lima, WHO/PAHO/ CEPIS, 1987.
17. Guidelines for drinking-water quality. Vol. 1, Recommendations. Geneva, World Health Organization, 1993.
18. Guidelines for drinking-water quality. Vol. 2, Health criteria and other supporting information. Geneva, World Health Organization, 1996.
19. Guy, H. 2007. "Design-Build and Trenchless." Proceedings of the ASCE Annual Pipelines Conference: Advances and Experiences with Trenchless Pipeline Projects, Boston, Massachusetts, July 8-11, 2007.
20. <http://lgam.wikidot.com/access-chamber>

21. Institution of Water Engineers, The Royal Institute of Chemistry, the Society for Analytical Chemistry and the Society for Water Treatment and Examination (1960) Approved methods for physical and chemical examination of water, 3rd ed., London, The Institution of Water Engineers
22. ISO 9000: "Introduction and support package; Guidance on the concept and use of the process approach for management systems" – document: ISO/TC 176/SC 2/N544R2, published 13 May 2004
23. Journal of the American Water Works Association, 1962, 54, No. 2
24. Kampbell, E. and L. Whittle. 2003. "QA/QC for Close-Fit Pipeline Renewal." Proceedings of the ASCE Annual Pipelines Conference: New Pipeline Technologies, Security, and Safety, Baltimore, Maryland, July 13-16, 2003.
25. Lloyd B, Helmer R. Surveillance of drinking water quality in rural areas. Harlow, England, Longman Scientific and Technical, 1991.
26. Manual of basic techniques for a health laboratory. Geneva, World Health Organization, 1980 (second edition in preparation).
27. NASSCO. 2009. Guideline Specification for the Replacement of Mainline Sewer Pipes by Pipe Bursting. http://www.nassco.org/publications/specs/spec_guidelines/pipebursting-ipba.pdf.
28. National Research Council (NRC). 2005. Public Water Supply Distribution Systems: Assessing and Reducing Risks, First Report. Washington, DC: The National Academies Press.
29. Panguluri, S., W. M. Grayman, and R. M. Clark. 2005. Distribution system water quality report: a guide to the assessment and management of drinking water quality in distribution systems. Cincinnati, OH: EPA Office of Research and Development.
30. Rajagopalan S, Shiffman MA. Guide to simple sanitary measures for the control of enteric diseases. Geneva, World Health Organization, 1974.
31. Selected physical and chemical standard methods for students. Washington, DC, American Public Health Association, 1990.
32. Small community water supplies—technology of small water supply systems in developing countries. The Hague, International Reference Centre for Community Water Supply and Sanitation, 1983.
33. Snyder, J. K., A. K. Deb, F. M. Grablutz, S. B. McCammon, W. M. Grayman, R. M. Clark, D. A. Okun, S. M. Tyler, and D. Savic. 2002. Impacts of fire flow on distribution system water quality, design and operation. Denver, CO: AwwaRF.
34. Standard methods for the examination of water and wastewater, 17th ed. Washington, DC, American Public Health Association, 1989.
35. Stinson, T. and J. Struzziery. 2007. "Lessons Learned –Lining Asbestos Cement Sewer Main." Proceedings of the ASCE Annual Pipelines Conference: Advances and Experiences with Trenchless Pipeline Projects, Boston, Massachusetts, July 8-11, 2007.
36. Surveillance of drinking-water quality. Geneva, World Health Organization, 1976 (WHO Monograph Series, No. 63).
37. United States, Public Health Service (1962) Public Health Service Drinking Water Standards, 1962, Washington, D. C. (US Public Health Service Publication, No. 9S6)
38. Von Huben, H. (Tech. Ed). 1999. Water distribution operator training handbook, 2nd edition. Denver, CO: AWWA.
39. Walski, T. M., D. V. Chase, and D. A. Savic. 2001. Water Distribution Modeling, 1st Edition. Waterbury, CT: Haestad Press.

40. Weber, Jr., W. 2004. Optimal uses of advanced technologies for water and wastewater treatment in urban environments. *Water Science and Technology: Water Supply* 4(1):7–12.

DRAWINGS

SPECIFICATIONS